



UPPSC – Polytechnic Lecturer

Electronics Engineering

Uttar Pradesh Public Service Commission (UPPSC)

Volume - 5

---

Analog Electronics & Measurement



# INDEX

S No.	Chapter Title	Page No.
1	Diodes Circuits	1
2	Bipolar Junction Transistor	33
3	Field Effect Transistor	73
4	Operational Amplifier and Application	80
5	Power Amplifier	119
6	Feedback Amplifier	128
7	Timer, Regulators & Filters	142
8	Sinusoidal Oscillators	160
9	Characteristics of Instrument and Measurement Systems	173
10	Analog Instruments	176
11	AC Bridges	196
12	Measurement of Power & Energy	206

# 1 CHAPTER

## Diodes Circuits

### THEORY

#### 1.1 BIASING

A diode can be biased in 2 ways, i.e., forward bias and reverse bias.

**Forward Bias :**

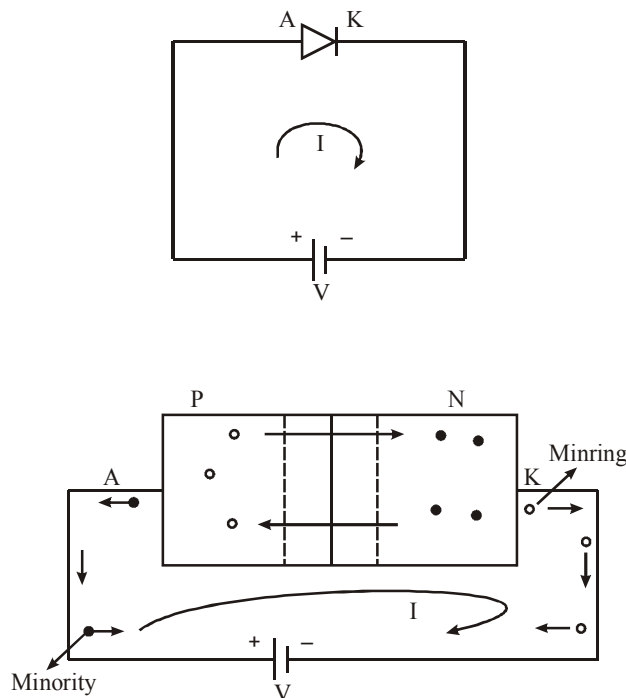

- The anode is connected to the positive terminal and cathode is connected to the negative terminal of the supply.
- The free carriers can cross over to the other side of the depletion layer when the applied forward bias voltage is just above the knee voltage.
- In this the free carrier are diffused across the junction and minority carriers are moving towards the battery.
- The depletion layer width, can become minimum.
- For a small change in the forward bias volume, there is a larger recombination of free carriers and there by the current is increasing exponentially.
- The forward bias voltage not only increase the energy of the free carriers, but also make the covalent bonds to break on both sides of the junction.

- With the applied forward bias, the number of free carriers less due to recombination can be generated due to breakage of covalent bonds.
- The diode can act like a closed switch.
- The V-I characteristics of the diode is a exponential growth and it can out like a non-linear device.

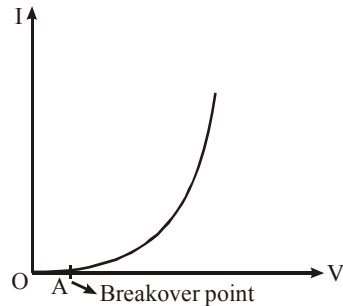

Forward current

$$I_f = I_0 (e^{V_d/\eta V_T} - 1)$$

$$V_T = \frac{kT}{q} = \frac{T}{11600}$$

$$I_f \approx I_0 e^{V_d/\eta V_T}$$

where  $v_d$  = voltage across diode  
 $\eta = 1$  for Ge, 2 for Si

**Reverse Bias :**

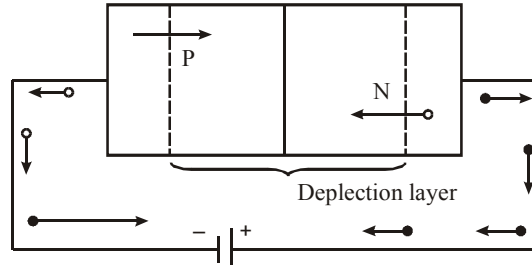

- The anode is converted to the negative terminal and the cathode connected to the positive terminal of the supply.
- The free carriers, i.e.,  $e^-$  s on n-side and holes on p-side are depleted (moving away) from the junction and move towards battery.
- The width of the depletion layer is increasing as increase in the reverse bias voltage.
- The minority carriers, i.e., holes on n-side and electrons on p-side can diffuse towards the junction.
- The current due to the free carriers is zero.
- The current is flowing due to the recombination of minority carriers and is of the order of ' $\mu A$ ' for Si.
- This minority current is also called reverse saturation current ' $I_0$ ' (or) ' $I_s$ '.
- The reverse current is independent of reverse bias volume and depend on temperature strongly.
- The reverse current doubles for every  $10^\circ C$  increase in temperature in Ge, where as in Si, it almost doubles for every  $6^\circ C$  increase in temperature
- In a R.B. the diode can out like a open switch.

- Equation of current in reverse bias

$$\therefore I_f = I_0 [e^{V_d/\eta V_T} - 1]$$

where  $V_d$  = Voltage across diode

= positive for forward bias

= negative for reverse bias

$$I_r = I_0 (e^{-V/\eta V_T} - 1)$$

$$\therefore e^{-V/\eta V_T} \ll 1$$

$$I_r \approx -I_0$$

(-) sign indicates that it is reverse bias and the current in reverse bias is independent of reverse bias voltage and depending strongly on temperature.

**V-I characteristics :**

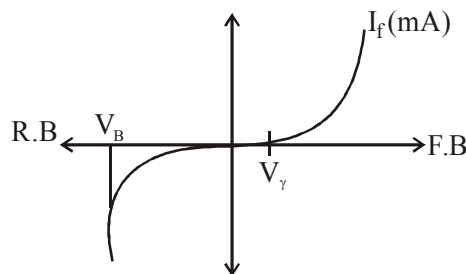

**Temperature Dependence of V-I characteristics :** Reverse saturation current approximately doubles for every  $10^\circ$  rise in temperature if  $I_0 = I_{01}$  at  $T = T_1$ , then at temperature  $T$ ,  $I_0$  is

$$I_0(T) = I_{01} \times 2^{(T-T_1/10)}$$

## 1.2 DIODE RESISTANCE

A resistance of a diode can be expressed in terms of static and dynamic.

**Static (or) DC Resistance :** It is expressed as the ratio of the voltage to the corresponding current at a given point of characteristic.

$$R_{DC} = \frac{V}{I} (\Omega)$$

The static resistance is valid only for linear devices, but diode is a non linear device.

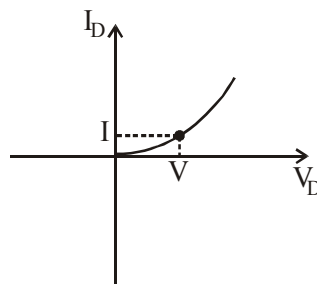

**Dynamic (or) AC Resistance :** The dynamic resistance is not constant and mainly depending on the operating voltage region.

The dynamic resistance is expressed as the reciprocal of the slope of the characteristic.

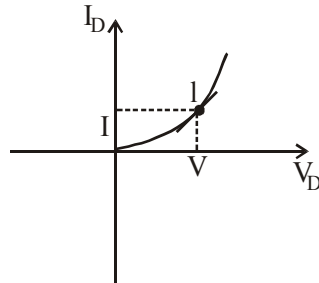

$$r_c = \frac{1}{\text{slope}} = \frac{1}{dI/dV} = \frac{dV}{dI} \Omega$$

$$r_{AC} = \frac{dV}{dI} = \frac{\eta K T}{qI} = \frac{\eta r_T}{I} \Omega$$

$$\therefore r_{AC} \propto \frac{1}{I}$$

For Ge at  $T = 300 \text{ k}$  (room temperature)

$$r_{AC} = \frac{26}{I} \Omega \quad [ \because \eta = 1, T = 300\text{k}, V_T = 26\text{mV} ]$$

For Si at  $T = 300 \text{ k}$

$$\therefore r_{AC} \propto \frac{52}{I} \Omega \quad [ \because \eta = 2 ]$$

**Example 1 :** Assume the Diode to be ideal, find the values of  $I$  and  $V$  in the circuit.

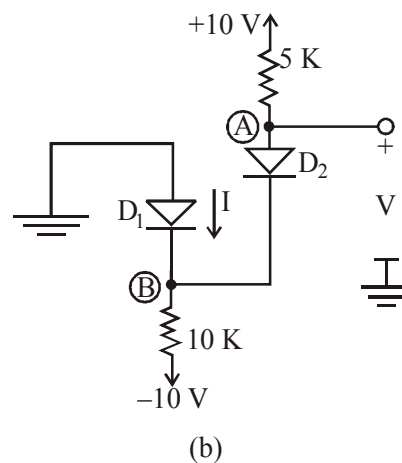
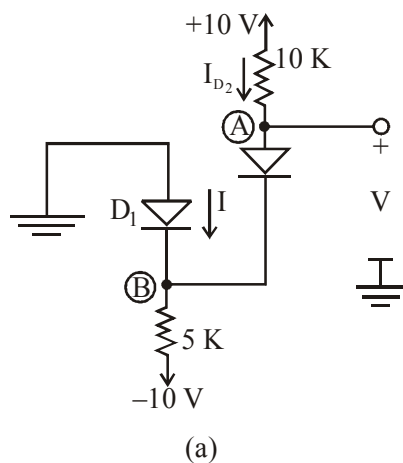

**Note :** In these circuits it might not be obvious at first sight whether none, one or both diode are conducting. In such cases we make a possible assumption, proceed with analysis, and then check whether we end up with consistent solution.

**Solution :** (a) Here we assume that both diodes are conducting. It follows that  $V_B = 0$  and  $V = 0$ . The current through  $D_1$  can now be determined from

$$I_{D_2} = \frac{10 - 0}{10K} = 1 \text{ mA}$$

Writing a node equation at B,

$$I + 1 = \frac{0 - (-10)}{5}$$

results in  $I = 1 \text{ mA}$ .

Thus  $D_1$  is conducting as originally assumed and final result is  $I = 1 \text{ mA}$  and  $V = 0 \text{ V}$ .

(b) For this circuit, if we assume that both diodes are conducting, then  $V_B = 0$  and  $V = 0$ . The current in  $D_2$  is obtained from,

$$I_{D_2} = \frac{10 - 0}{5} = 2 \text{ mA}$$

node equation at B is,

$$I + 2 = \frac{0 - (-10)}{10}$$

$$I = -1 \text{ mA}$$

Which is not possible as this would mean that current in  $D_1$  flows from n to p.

So, we start again, assuming that  $D_1$  is OFF and  $D_2$  is ON. The current  $I_{D_2}$  is given by,

$$I_{D_2} = \frac{10 - (-10)}{15} = 1.33 \text{ mA}$$

and voltage at node B is

$$V_B = -10 + 10 \times 1.33 = + 3.3 \text{ V}$$

Thus,  $D_1$  is reverse biased and  $I = 0$  and  $V = 3.3 \text{ V}$ .

**Example 2 :** Find  $I$  and  $V_0$ , ideal diode is forward bias and short circuit.

**Solution :**

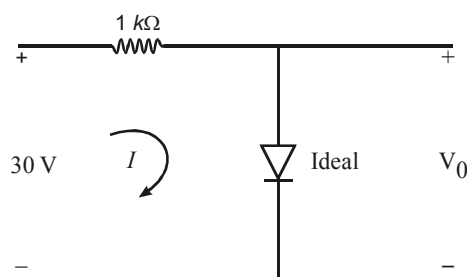

$$I = \frac{30}{1K} = 30 \text{ mA}$$

$$V_0 = 0 \text{ Volt}$$

**Example 3 :** Find  $I$  and  $V_o$ , ideal diode is forward bias and short circuit.

**Solution :**

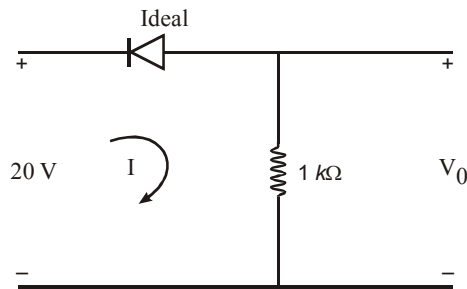

$$V_o = -20V$$

$$I = \frac{-20}{1K} = -20 \text{ mA}$$

**Example 4 :** Find  $V_o$ ,  $I$ ,  $I_D$  and  $I_R$ , Ideal diode is forward bias and short circuit.

**Solution :**

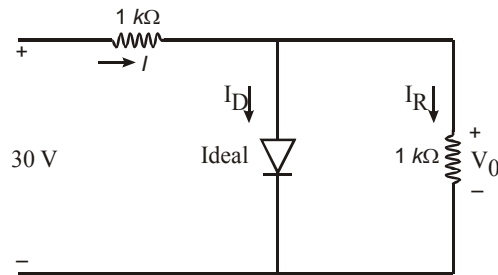

$$V_o = 0$$

$$I_R = 0$$

$$I_D = \frac{30 \text{ V}}{1K} = 30 \text{ mA}$$

$$I = I_D = 30 \text{ mA}$$

**Example 5 :** Find  $V_o$ ,  $I$ ,  $I_D$  and  $I_R$ , ideal diode is reverse bias and output current.

**Solution :**

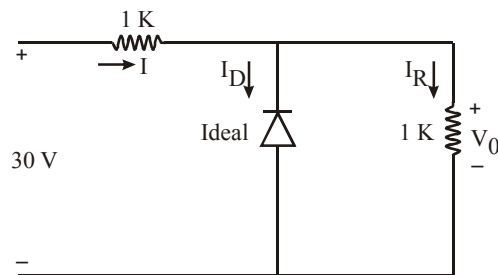

$$I_D = 0$$

$$I = I_R = \frac{30}{1K + 1K} = 15 \text{ mA}$$

$$V_o = 30 \times \frac{1}{1+1} = 15V$$

**Example 6 :** Find  $I$  and  $V_0$ . Ideal diode forward bias and SC.

**Solution :**

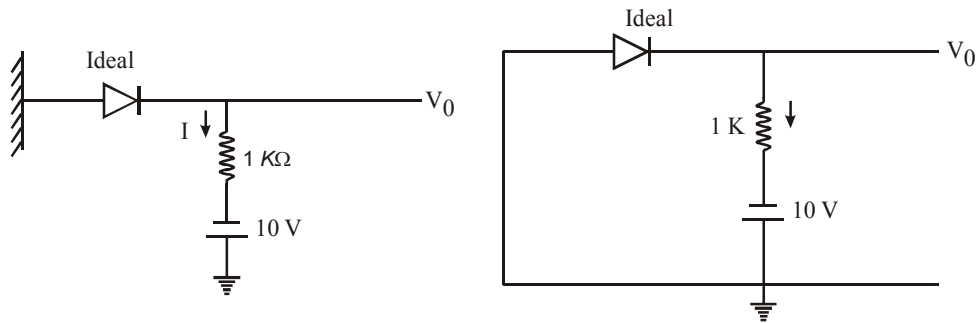

$\therefore$  Ideal diode is forward bias and short circuit

$$\therefore V_0 = 0$$

and  $0 - I \times 1K + 10V = 0$

$$I = \frac{10}{1K} = 10\text{mA}$$

**Example 7 :** Find  $Z_{AB}$

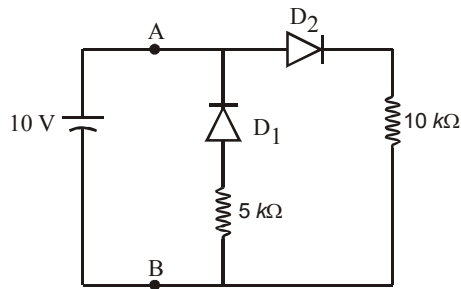

**Solution :** A is positive w.r.t. B.

$D_1$  is reverse bias and open circuit

$D_2$  is forward bias and short circuit.

$$Z_{AB} = 10k\Omega$$

**Example 8 :** Find which diode is conducting in the given circuit and also find  $e_0$ .

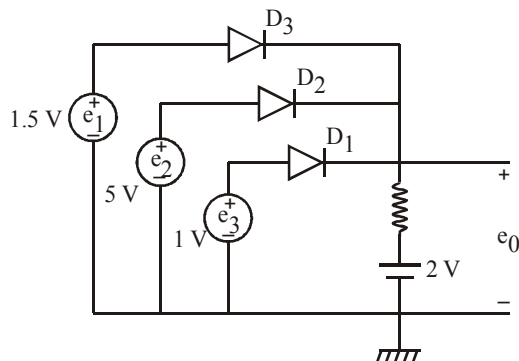

**Solution :**

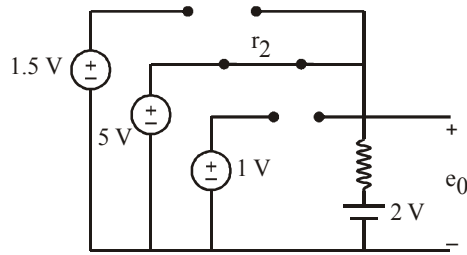

$D_1$  and  $D_3$  are in reverse bias.

$D_2$  is forward bias and conducting.

$$e_0 = 5V$$

**Example 9 :** Find the voltage  $V_1$  and  $V_2$  of the arrangement given in the figure respectively :

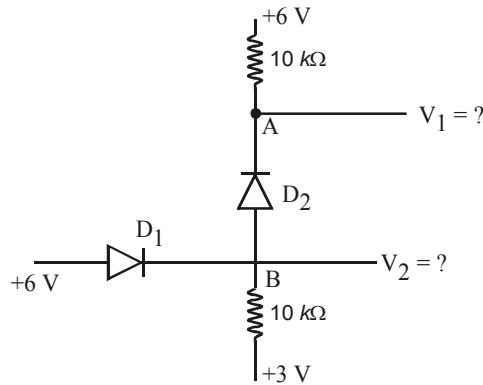

**Solution :** At node A voltage is less than 6 volt due to drop in resistor  $10\text{ k}\Omega$ . So diode  $D_2$  is forward bias and SC.

$$\therefore V_1 = V_2 = 6V$$

**Example 10 :** If  $D_1$  and  $D_2$  are ideal diode find the current  $I_1$ .

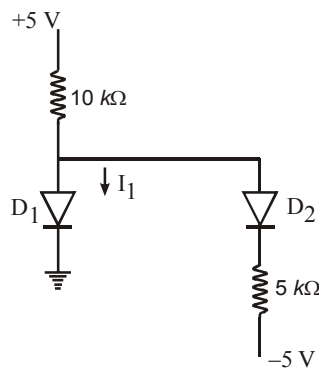

**Solution :**

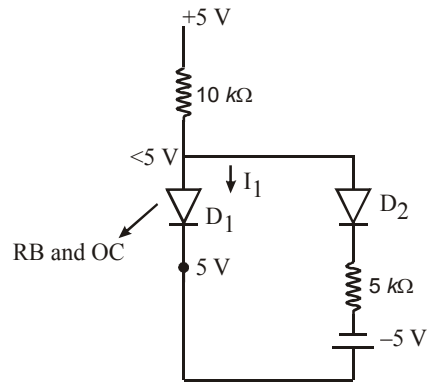

From the figure  $D_1$  is reverse bias and open circuit.

$\therefore I_1 = 0$

**Example 11 :**

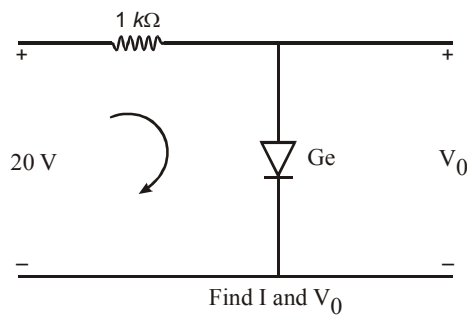

Find  $I$  and  $V_0$ , Ge diode is forward bias.

**Solution :**

$$V_0 = V_{Ge} = 0.2V$$

$$I = \frac{20 - V_{Ge}}{1K} = \frac{20 - 0.2}{1K} = 19.8 \text{ mA}$$

**Example 12 :** Find  $I$  and  $V_0$ .

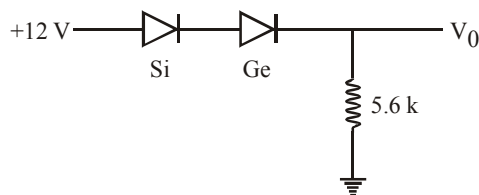

**Solution :**

$$I = \frac{12 - 0.7 - 0.2}{5.6K} = 1.982 \text{ mA}$$

$$V_0 = 12 - 0.7 - 0.2 = 11.1 \text{ Volt}$$

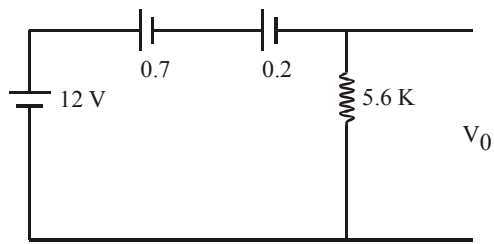

**Example 13 :** Find I and  $V_0$ .

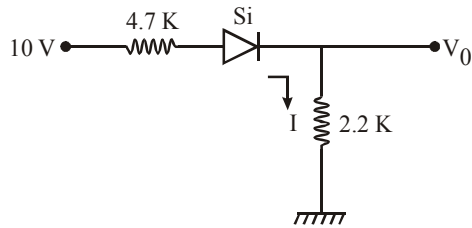

**Solution :**

$$I = \frac{10 - V_r}{4.7\text{ K} + 2.2\text{ K}} = \frac{10 - 0.7}{4.7\text{ K} + 2.2\text{ K}} = 1.347\text{ mA}$$

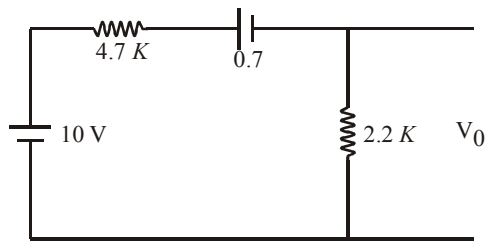

$$V_0 = 1.347 \times 2.2 = 2.965\text{ V}$$

**Example 14 :** Find I and  $V_0$ .

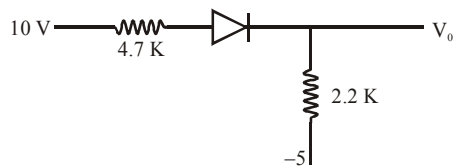

**Solution :**

$$I = \frac{10 - 0.7 + 5}{(4.7 + 2.2)\text{K}} = 2.072\text{ mA}$$

$$V_0 = I \times (2.2\text{ K}) - 5 = 2.072\text{ mA} \times 2.2\text{K} - 5 = -0.4416\text{ Volt}$$

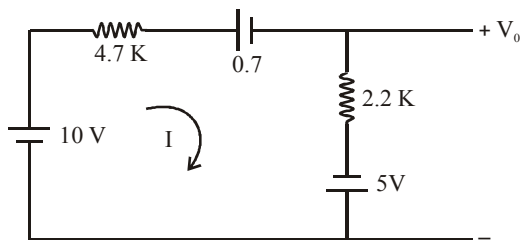

**Example 15 :** Find I

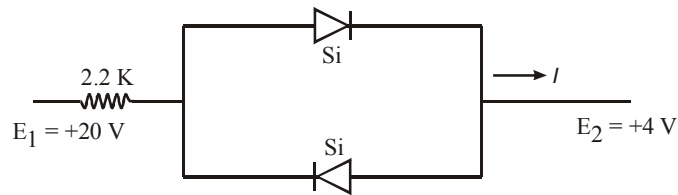

**Solution :** Since  $E_1 > E_2$ . Bottom diode is reverse bias and open circuit upper diode is forward bias and SC.

$$I = \frac{20 - 0.7 - 4}{2.2K} = 6.95 \text{ mA}$$

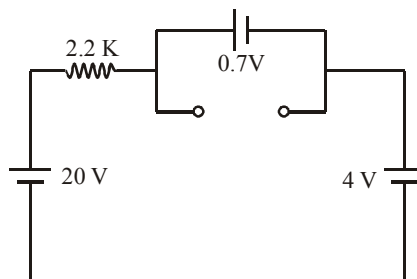

**Example 16 :** Find  $V_0$ .

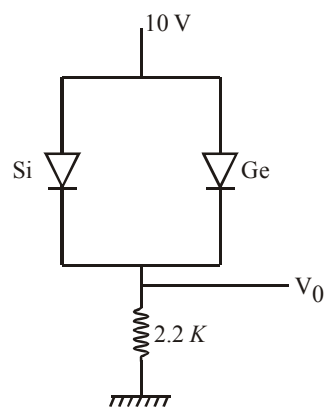

**Solution :** When 10 V is applied both Ge and Si diode both are forward bias and due to smaller cut in voltage Ge will enter into conduction.

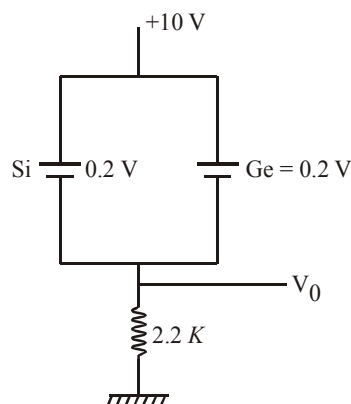

$$V_0 = 10 - V_{Ge} = 10 - 0.2 = 9.8V$$

Si diode is forward bias but not conducting as the forward voltage is less than cut in voltage.

**Example 17 :** Find  $I_D$ .

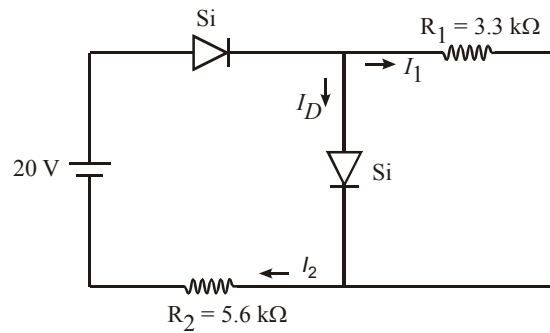

**Solution :**

$$V_{R_1} = V_{rSi} = 0.7V$$

$$I_1 = \frac{0.7}{3.3K} = 0.212 \text{ mA}$$

$$I_2 = \frac{20 - 0.7 - 0.7}{5.6} = 3.321 \text{ mA}$$

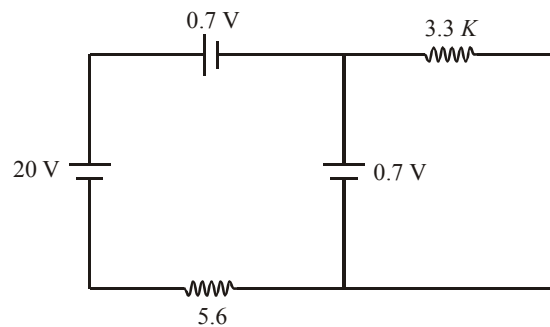

$$I_D = I_2 - I_1 = 3.321 - 0.212 = 3.109 \text{ mA}$$

**Example 18 :** Find  $V_{01}$  and  $V_{02}$ .

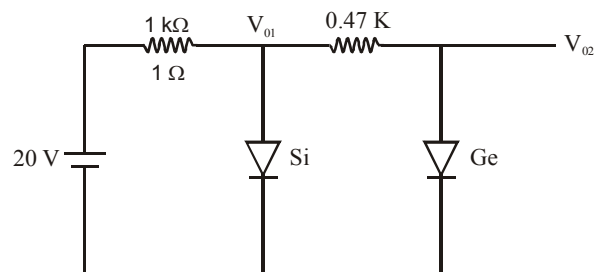

**Solution :**

$$V_{01} = 0.7V = V_{rSi}$$

$$V_{02} = 0.2V = V_{rGe}$$

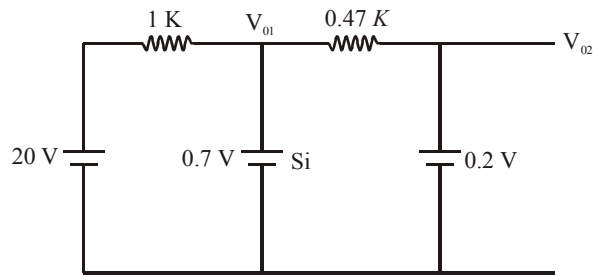

**Example 19 :** Find  $I_1$ ,  $I_2$  and  $I_D$ .

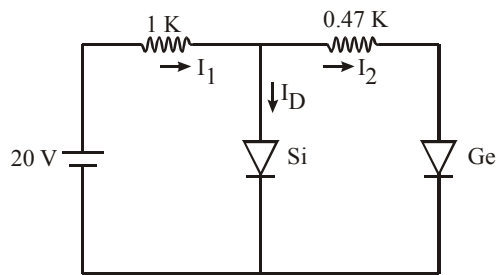

**Solution :**

$$I_1 = \frac{20 - 0.7}{1K} = 19.3 \text{ mA}$$

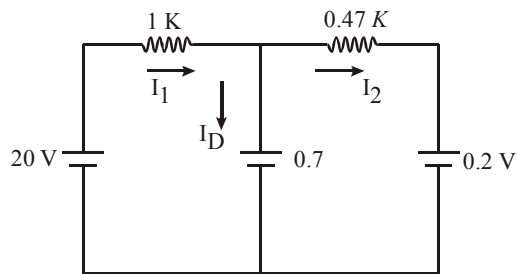

$$I_2 = \frac{0.7 - 0.2}{0.47K} = 1.063 \text{ mA}$$

$$I_D = 19.3 \text{ mA} - 1.063 \text{ mA} = 18.237 \text{ mA}$$

**Example 20 :** Find  $I$ ,  $V_1$  and  $V_0$ .

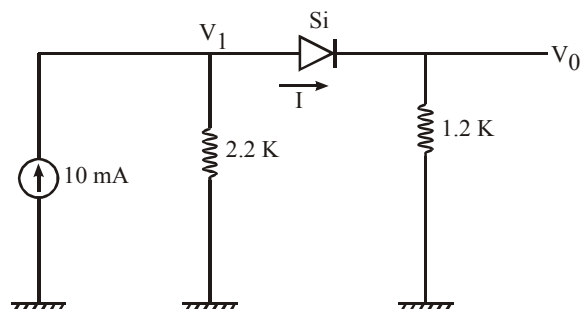

**Solution :**

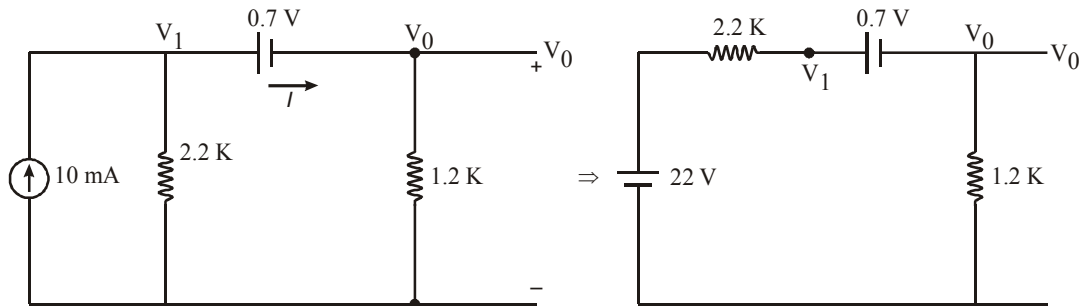

$$I = \frac{22 - 0.7}{2.2\text{K} + 1.2\text{K}} = 6.26 \text{ mA}$$

$$V_0 = I \times 1.2 \text{ K} = 6.26 \times 1.2 = 7.51 \text{ Volt}$$

$$V_1 = 22 - (2.2 \times 6.26) = 8.228 \text{ Volt}$$

or

$$V_0 = V_1 - V_{rSi} = 8.228 - 0.7 = 7.51 \text{ Volt}$$

**Example 21 :** Find  $V_0$  and  $I_1$ .

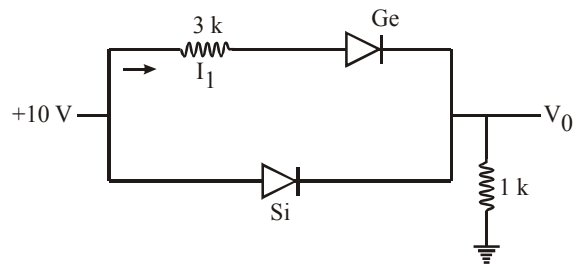

**Solution :**

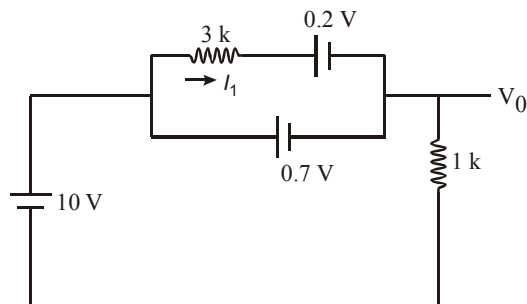

$$V_{rSi} = V_{rGe} + 3 \times I_1 \Rightarrow 0.7\text{V} = 0.2\text{V} + 3 \times I_1$$

$$I_1 = \frac{0.5}{3} = 0.166 \text{ mA}$$

$$V_0 = 10 - V_{rSi} = 10 - 0.7 = 9.3 \text{ Volt}$$

**Example 22 :** The cut in voltage for each diode is 0.6 volt and each diode current is 0.5 mA. Find the values of  $R_1$ ,  $R_2$  and  $R_3$ .

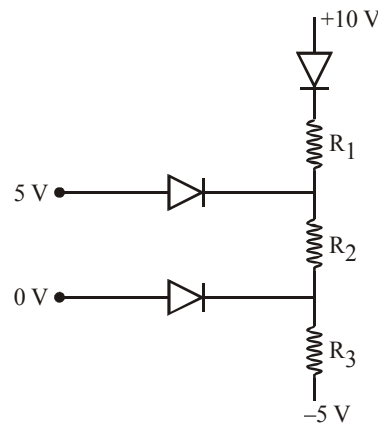

**Solution :**

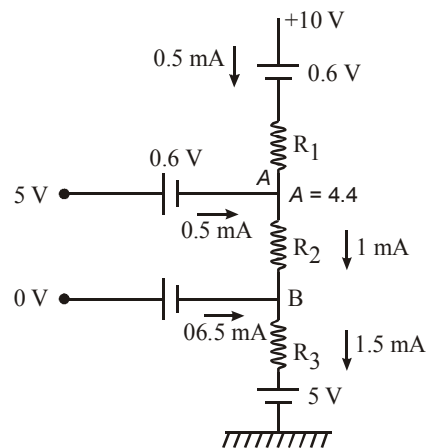

$$V_A = 5 - V_r = 5 - 0.6 = 4.4 \text{ Volt}$$

$$V_B = 0 - 0.6 = -0.6 \text{ Volt}$$

$$V_{AB} = V_A - V_B = 4.4 - (-0.6) = 5V$$

$$R_1 = \frac{10 - V_r - V_A}{0.5 \text{ mA}} = \frac{10 - 0.6 - 4.4}{0.5 \text{ mA}} = 10 \text{ k}\Omega$$

$$R_2 = \frac{V_A - V_B}{1 \text{ mA}} = \frac{5V}{1 \text{ mA}} = 5 \text{ k}\Omega$$

$$R_3 = \frac{V_B - (-5)}{1.5} = \frac{-0.6 + 5}{1.5} = 2.93 \text{ k}\Omega$$

### 1.3 CLIPPERS

Clippers are networks that employ diodes to “clip” away a portion of an input signal without distorting the remaining part of the applied waveform.

#### (i) Positive Clippers :

**Circuit - 1 :**

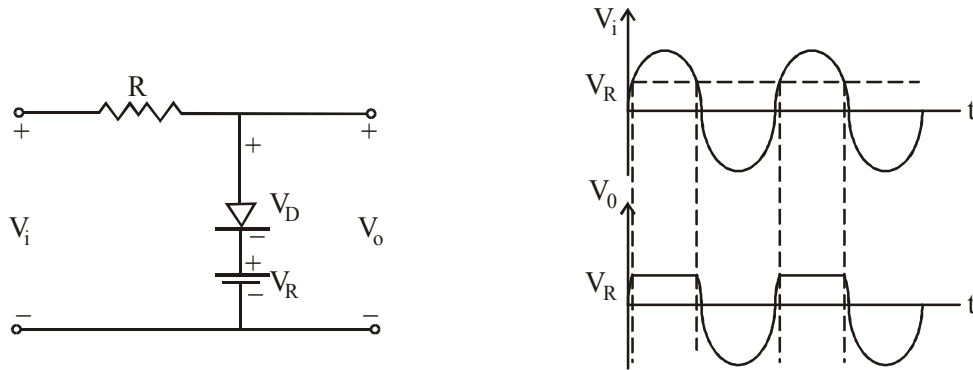

$V_i$	Diode	$V_o$
$V_i < V_R$	OFF	$V_i$
$V_i > V_R$	ON	$V_R$

**Circuit - 2 :**

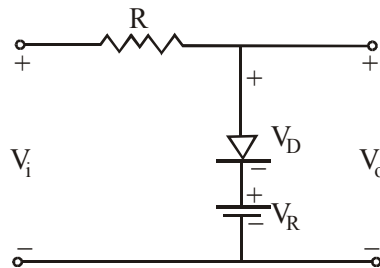

When  $V_D > 0$  or  $V_i < -V_R$ , Diode  $\rightarrow$  OFF  
 $V_o = V_i$

When  $V_D < 0$  or  $V_i > -V_R$ , Diode  $\rightarrow$  ON  
 $V_o = -V_R$

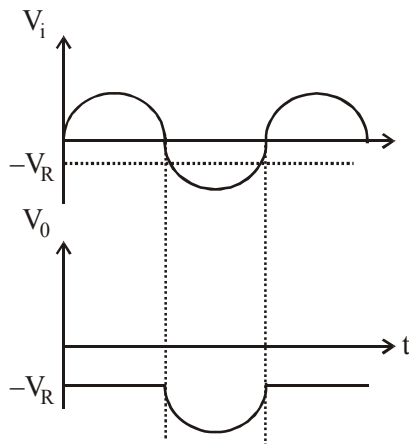

**(ii) Negative Clippers :**

**Circuit - 1 :**

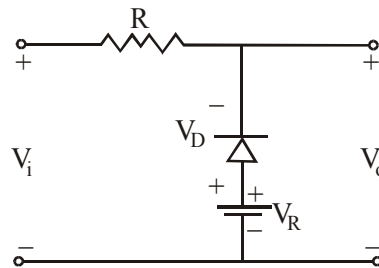

When  $V_i > V_R$  Diode  $\rightarrow$  OFF

$$V_o = V_i$$

When  $V_i < V_R$  Diode  $\rightarrow$  ON

$$V_o = V_R$$

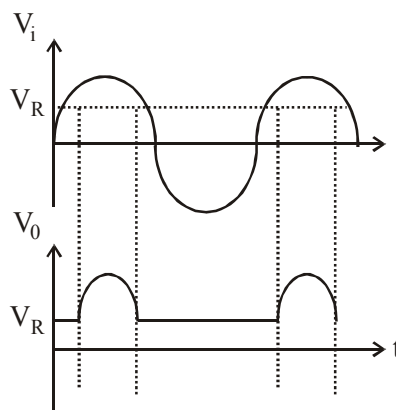

**Circuit - 2 :**

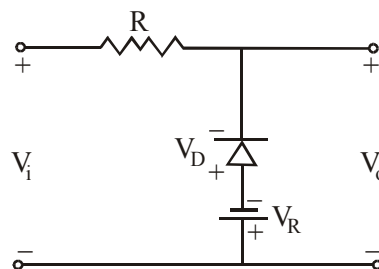

When  $V_i < -V_R$ , Diode  $\rightarrow$  ON

$$V_o = -V_R$$

When  $V_i > -V_R$  Diode  $\rightarrow$  OFF

$$V_o = V_i$$

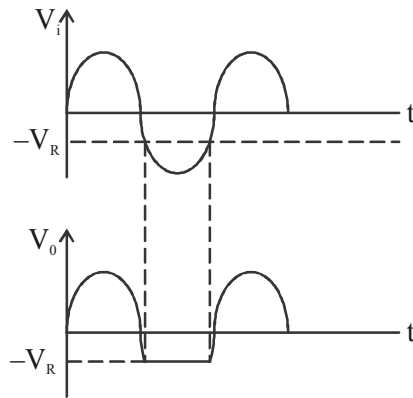

**Some other types of Clipper Circuit :**

**Type - 1 :**

When  $V_i > V_R$  Diode  $\rightarrow$  ON  $V_o = V_i$

When  $V_i < V_R$  Diode  $\rightarrow$  OFF  $V_o = V_R$

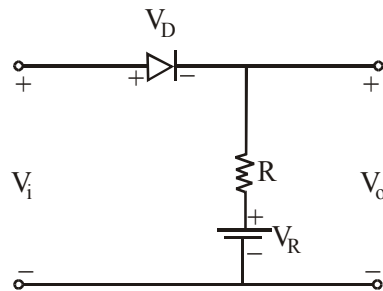

$$V_i = V_D + V_R$$

$$V_D = V_i - V_R$$

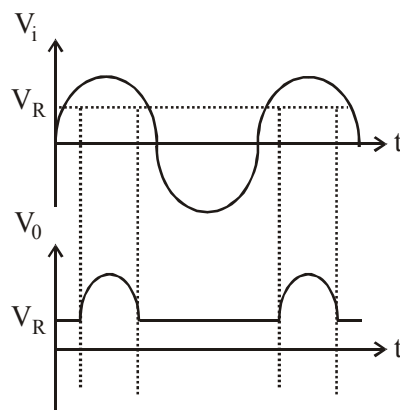

**Type - 2 :**

When  $V_i > -V_R$ , Diode  $\rightarrow$  ON  $V_o \rightarrow V_i$

When  $V_i < -V_R$ , Diode  $\rightarrow$  OFF  $V_o \rightarrow -V_R$