



UKPSC – JE

Civil Engineering

Uttarakhand Public Service Commission (UKPSC)

Volume - 9

(Technical)

Design of Steel Structures



INDEX

S No.	Chapter Title	Page No.
1	Steel Structures Introduction	1
2	Connections	9
3	Tension Members	59
4	Compression Members	73
5	Beams	107
6	Gantry and Plate Girders	124
7	Plastic Analysis	144
8	Industrial Buildings	164
9	Steel Structures Summary of Codes	170

1 CHAPTER

Steel Structures Introduction

THEORY

1.1 OBJECTIVE OF DESIGN

The objective of design is the achievement of an acceptable probability that structures will perform satisfactorily for the intended purpose during the design life. They should sustain all the loads and deformations during construction and use and have adequate resistance to accidental loads and fire with an appropriate degree of safety.

1.2 METHODS OF DESIGN

1.2.1 Working Stress Method as per IS 800 : 1984

The stresses used in practical design are termed as working stresses or safe working stresses. These should never exceed the permissible stresses listed in table.

Permissible Stresses in Steel Structural Members

S.No.	Types of stress	Notation	Permissible Stress (MPa)	Factor of Safety
1.	Axial tensile stress	σ_{at}	$0.6 f_y$	1.67
2.	Maximum axial compressive stress	σ_{ac}	$0.6 f_y$	1.67
3.	Bending tensile stress	σ_{bt}	$0.66 f_y$	1.515
4.	Maximum bending compressive stress	σ_{bc}	$0.66 f_y$	1.515
5.	Average shear stress	τ_{va}	$0.4 f_y$	2.5
6.	Maximum shear stress	τ_{vm}	$0.45 f_y$	2.22
7.	Bearing stress	σ_p	$0.75 f_y$	1.33
8.	Stress in slab base	σ_{bs}	185	–

The permissible stresses are some fraction of the yield stress of the material.

It is defined as the ratio of the yield stress to the factor of safety.

The concept of introducing a factor of safety is to make the structure safe to the account for the following :

1. The analysis methods are based on assumptions and do not give the exact stresses.
2. Structural members may be temporarily overloaded under certain circumstances.
3. The stresses due to fabrication and erection are not considered in the design of ordinary structures.
4. The secondary stresses may be appreciable.
5. Underestimation of the future live loads.
6. Stress concentrations.
7. Unpredictable natural calamities.

1.2.2 Limit State Method as per IS 800 : 2007

Limit State method should be used to design structure and its elements as per IS 800 : 2007. The design strength is the ultimate strength. Where the limit state method cannot be conveniently adopted, working stress method can be used.

1.3 LOADS AND FORCES

For the purpose of designing any element, member or a structure, the following loads and their effects shall be taken into account, where applicable, with partial safety factors and combinations :

- Dead loads; *[DL]*
- Imposed loads; (Live load, crane load, snow load etc.) *[IL]*
- Wind loads *[WL]*
- Earthquake loads *[EL]*
- Erection loads *[ER]*
- Accidental loads such as those due to blast *[AL]*
- Secondary effects due to contraction or expansion resulting from temperature changes, differential settlements of the structure as a whole or of its components, eccentric connections.

1.3.1 Load Combinations

The following load combinations with appropriate load factors may be considered in designing

- Dead load + Imposed load
- Dead load + Imposed load + Wind or Earthquake load
- Dead load + Wind or Earthquake load
- Dead load + Erection load

1.4 BASIS OF CLASSIFICATION OF CROSS SECTIONS AS PER IS 800-2007

When plastic analysis is used, the members shall be capable of forming plastic hinges with sufficient rotation capacity (ductility) without local buckling to enable the redistribution of bending moment required before formation of failure mechanism.

The plate elements of a cross-section may buckle locally due to compressive stresses.

When elastic analysis is used, the member shall be capable of developing the yield stress under compression without local buckling.

On the above basis, four classes of sections are defined as follows:

- **Semi-compact** : Cross-sections, in which the extreme fibre in compression can reach, yield stress, but cannot develop the plastic moment of resistance, due to local buckling.
- **Slender** : Cross-sections in which the elements buckle locally even before reaching yield stress.

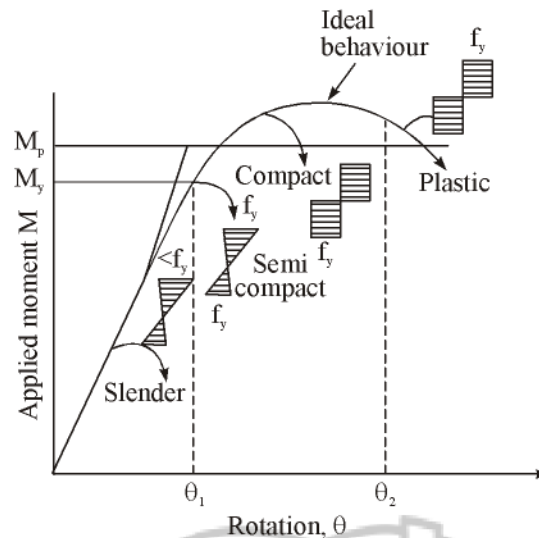

Moment-rotation behaviour of the four classes of cross-sections.

- **Plastic** : Cross-sections, which can develop plastic hinges and have the rotation capacity required for failure of the structure by formation of a plastic mechanism.
- **Compact**: Cross-sections, which can develop plastic moment of resistance, but have inadequate plastic hinge rotation capacity for formation of a plastic mechanism.

1.4.1 Geometric Properties of Cross-section

IS 800-2007 gives the concept of the gross and effective cross-sections of a member.

- The properties of the gross cross-section shall be calculated from the specified size of the member or read from appropriate table.
- The effective cross-section of a member is that portion of the gross cross-section that is effective in resisting the stresses.

1.5 BASIS FOR LIMIT STATE DESIGN OF STEEL STRUCTURES

In the limit state design method, the structure shall be designed to withstand safely all loads likely to act on it throughout its life. It shall also satisfy the serviceability requirements, such as limitations of deflection and vibrations and shall not collapse under accidental loads such as from explosions or impact or due to consequences of human error to an extent not originally expected to occur.

The acceptable limit for the safety and serviceability requirements before failure occurs is called a limit state. The objective of design is to achieve a structure that will not become unfit for use with an acceptable target reliability.

In other words, the probability of a limit state being reached during its lifetime should be very low. In general, the structure shall be designed on the basis of the most critical limit state and shall be checked for other limit states.

1.6 LIMIT STATE DESIGN CLASSIFICATIONS

Limit states are the states beyond which the structure no longer satisfies the performance requirements specified. The limit states are classified as :

- Limit State of Strength
- Limit State of Serviceability

1.6.1 Limit State of Strength

The limit state of strength are those associated with failures (or imminent failure), under the action of probable and most unfavourable combination of loads on the structure.

1.6.2 Limit State of Serviceability

The limit state of serviceability includes :

- Deformations and deflections
- Vibrations
- Repairable damage due to fatigue
- Corrosion and durability

The major innovation in the limit state method is the introduction of the partial safety factor. Which essentially splits the factor of safety into two factors - one for the material and one for the load.

In accordance with these concepts, the safety format used in limit state codes is based on probable maximum load and probable minimum strengths. So that a consistent level of safety is achieved.

Thus, the design requirements are expressed as follows :

$$f_d \leq S_d$$

where

f_d = Value of internal forces and moments caused by factored design loads F_d .

$$F_d = \gamma_f \times \text{characteristic loads}$$

γ_f = Partial safety factor for load

γ_m = Partial safety factor for material

S_u = Ultimate strength

S_d = Design strength

$$S_u = \gamma_m \times S_d$$

Both the partial factors for load and material are determined on a probabilistic basis of the corresponding quantity. It should be noted that γ_f makes allowance for possible deviation of loads and also the reduced possibility of all loads acting together.

On the otherhand γ_m allows for uncertainties of element behaviour and possible strength reduction due to manufacturing tolerances and imperfections in the materials.

1.7 SERVICE CRITERIA UNDER LIMIT STATES OF SERVICEABILITY

The deflection under serviceability loads of a building or a building component should not impair the strength of the structure or components or cause damage to finishing.

Table below gives the limits of deflections for certain structural members systems as recommended by IS 800-2007.

Deflection Limit as per IS 800:2007

Type of building	Deflection	Design Load	Member	Supporting	Maximum deflection
Individual Buildings	Vertical	Live Load / Wind load	Purlins and Girts	Elastic cladding Brittle cladding	Span/150 Span/180
		Live load	Simple span	Elastic cladding Brittle cladding	Span/240 Span/300
		Live load	Cantilever span	Elastic cladding Brittle cladding	Span/120 Span/150
		Live load / Wind load	Rafter supporting	Profiled metal sheeting Plastered sheeting	Span/180 Span/240
		Crane load (manual operation)	Gantry	Crane	Span/500
		Crane load (Electric operation over 50t)	Gantry	Crane	Span/750
		Crane load (Electric operation over 50t)	Gantry	Crane	Span/1000
	Lateral	No cranes	Column	Elastic cladding Masonry/Brittle cladding Crane (absolute)	Height/150 Height/240 Span/400
		Crane + wind	Gantry (lateral)	Relative displacement between rails supporting crane	10 mm
		Crane + wind	Column/frame	Gantry (Elastic cladding, pendent operated) Gantry (Brittle cladding, cab operated)	Height/200 Height/400
Other Buildings	Vertical	Live load	Floor and roof	Elements not susceptible to cracking Elements susceptible to cracking	Span/300 Span/360
		Live load	Cantilever	Elements not susceptible to cracking Elements susceptible to cracking	Span/150 Span/180
	Lateral	Wind	Building	Elastic cladding Brittle cladding	Height/300 Height/500
		Wind	Inter storey drift		Storey height / 300

Deflections are to be checked for the most adverse but realistic combination of service loads and their arrangement, by elastic analysis, using a load factor of 1.0.

Where the deflection due to dead load plus live load combination is likely to be excessive, consideration should be given to pre-camber the beams, trusses and girders. Generally for spans greater than 25 m, camber approximately equal to the deflection due to dead loads plus half the live load, may be used.

- The deflection of a member shall be calculated without considering the impact factor or dynamic effect of the loads on deflection.
- Roofs, which are very flexible, shall be designed to withstand any additional load that is likely to occur as a result of ponding of water or accumulation of snow.

1.7.1 Vibration

Suitable provisions in the design shall be made for the dynamic effects of live loads impact loads and vibration due to machinery operating loads. In severe cases possibility of resonance, fatigue or unacceptable vibrations shall be investigated.

1.7.2 Durability

Several factors affecting the durability of the buildings, under conditions relevant to their intended life are listed below:

- The environment
- The degree of exposure
- The shape of the member and the structural detailing
- The protective measure
- Ease of maintenance

IS: 800:2007 specifies the requirement of durability and also specifications for different coating system under different exposure conditions.

Five exposure conditions have been specified mild, moderate, severe, very severe and extreme.

“It should be noted that code does not specify any minimum thickness for members. The earlier code 800:1984 specified a minimum thickness of 6 mm for members directly exposed to weather and fully accessible for cleaning and repainting and 8mm for members directly exposed to weather but not accessible for cleaning repainting.”

It is assumed that if durability requirements as given in section 15 (IS 800) are followed, it will ensure adequate protection for all thickness.

1.7.3 Fire Resistance

Fire resistance of a steel member is a function of its mass, its geometry, the actions to which it is subjected, its structural support conditions, fire protection measures adopted and the fire to which it is exposed.

1.7.4 Fatigue

Fatigue limit state is important when repeated loading is considered. It is important in case of bridges, crane girders, platform carrying vibrating machines.

As per code, stress changes due to fluctuations in wind loading need not be considered as fatigue. Fatigue failure is normally considered as ultimate limit state but fatigue checks are carried out at working load ($\gamma_f = 1$).

This is because fatigue failure occurs due to large no. of application of loads normally expected to act on the structure (service load).

Section 13 (As per IS 800) of code gives the guidelines for fatigue design but does not consider the effect of following,

- Corrosion fatigue
- low cycle (high stress) fatigue
- Thermal fatigue
- stress corrosion cracking
- effect of high temperature
- effect of low temperature

Code states that fatigue assessment is not normally required for building structures except in the following members.

- Those supporting lifting or rolling loads
- Those subjected to repeated stress cycles from vibrating machine
- These subjected to wind induced oscillations for a large number of cycles in life
- Those subjected to crowd induced oscillations of a large number of cycles in life.

For the purpose of design against fatigue, code classifies different details (of members and connections) under different fatigue classes.

1.7.5 Brittle Fracture

As with fatigue, brittle fracture will rarely occur in building constructions. Such fracture is the sudden failure of the material under service condition, caused by low temperature or sudden change in stress. Since thick material is more prone to brittle fracture than thin material, limiting thickness are often prescribed by the codes for the various members.

□□□

ENGINEERS ACADEMY

2 CHAPTER

Connections

THEORY

2.1 BASIS OF DESIGN

Connections (or structural joints) may be classified according to the following parameters:

- Method of fastening such as rivets, bolts, and welding — connections using bolts are further classified as bearing or friction type connections
- Connection rigidity — Simple, rigid (so that the forces produced in the members may be obtained by using an indeterminate structural analysis), or semi-rigid

It is desirable to avoid connection failure before member failure due to the following reasons.

- A connection failure may lead to a catastrophic failure of the whole structure.
- Normally, a connection failure is not as ductile as that of a steel member failure.
- For achieving an economical design, it is important that connectors develop full or a little extra strength than the members that it is joining.

According to the IS code, based on connection rigidity, the joints can be defined as follows:

2.1.1 Rigid Connections

Rigid connections develop the full moment capacity of connecting members and retain the original angle between the members under any joint rotation, that is rotational movement of the joint will be very small on these connections.

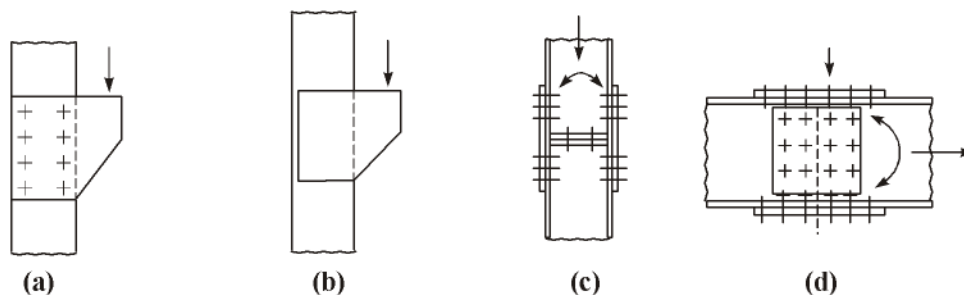

Example of 'rigid' connections (Martin and Purkiss 1992)

2.1.2 Simple Connections

In simple connections no moment transfer is assumed between the connected parts and hence are assumed as hinged (pinned).

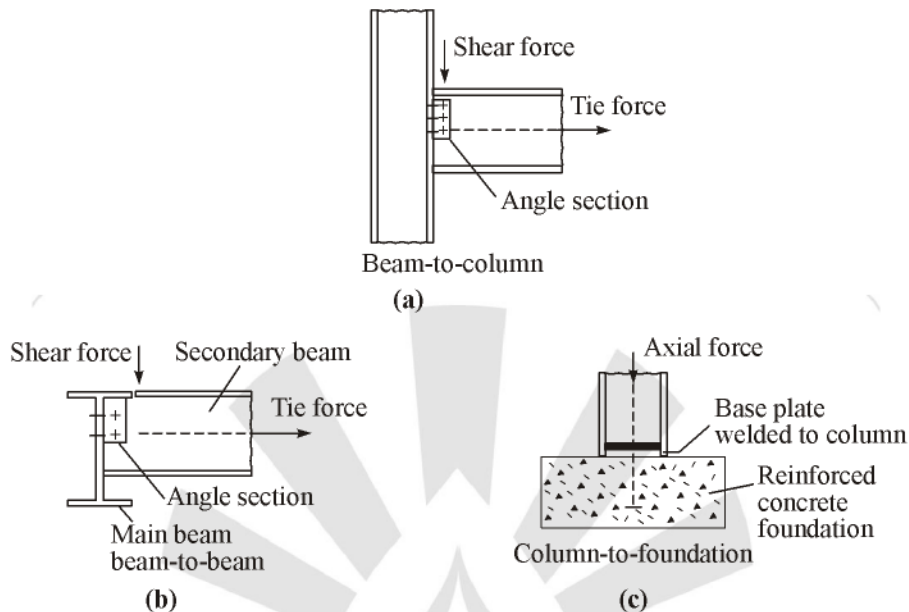

Examples of 'pinned' connections (Martin and Purkiss 1992)

- The rotational movement of the joint will be large in this case. Actually, a small amount of moment will be developed but is normally ignored in the design. Any joint eccentricity less than about 60 mm is neglected.

2.1.3 Semi-Rigid Connections

Semi-rigid connections may have sufficient rigidity to hold the original angles between the members and develop less than the full moment capacity of the connected member.

- In reality, all the connections will be semi-rigid. However, for convenience we assume some of them as rigid and some as hinge.

2.2 CONNECTION

The following three types of connections may be made in steel structures :

- Riveted
- Bolted
- Welded

2.2.1 Riveted Connections

Riveting is a method of joining together pieces of metal by inserting ductile metal pins called rivets into holes of pieces to be connected and forming a head at the end of the rivet to prevent each metal piece from coming out.

- The diameter of the shank is called the Nominal Diameter.
- When the rivets are heated before driving they are called Hot Driven Field Rivets or Hot Driven

Shop Rivets, depending upon if they are placed in the field or in the workshop.

- The Diameter of the rivets when hot is equal to the diameter of the hole and is called gross diameter.
- The hot rivet becomes plastic, expands and fills the rivet hole completely in the process of forming a head at the other end. On cooling, the rivet shrinks both in length and diameter.
- Rivet holes are made in the structural members to be connected by punching or by drilling. The size of rivet hole is kept slightly more (1.5 to 2.0 mm) than the size of rivet.
- After the rivet holes in the members are matched, a red hot rivet is inserted which has a shop made head on one side and the length of which is slightly more than the combined thicknesses of the members to be connected.
- Then holding red hot rivet at shop head end, hammering is made.
- It results in to expansion of the rivet to completely fill up the rivet hole and also into formation of driven head.
- Desired shapes can be given to the driven head.
- The riveting is done may be in the workshops or in the field.

Riveting has the following disadvantages :

- High level of noise pollution.
- Needs heating the rivet to red hot.
- Inspection of connection is a skilled work.
- Removing poorly installed rivets is costly.
- High labour cost

Production of weldable quality steel and introduction of high strength friction grip bolts have replaced use of rivets.

Design procedure for riveted connections is same as that for bolted connection except that the effective diameter of rivets may be taken as rivet hole diameter instead of nominal diameter of rivet
IS 800-2007 do not discuss riveted connection, it is consider in IS 800:1984

2.2.2 Bolted Connections

A bolt is a metal pin with a head formed at one end and shank threaded at the other in order to receive a nut. Bolts are used for joining together pieces of metals by inserting them through holes in the metal and tightening the nut at the thread ends.

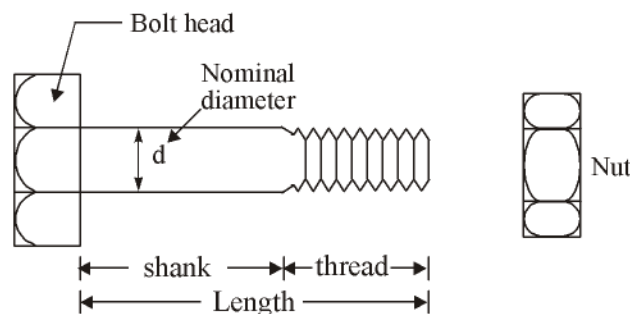

Fig. : Bolt and Nut

2.3 CLASSIFICATION OF BOLTS

Bolts are classified as :

- Unfinished (black) bolts
- Finished (turned) bolts
- High strength friction grip (HSFG) bolts

2.3.1 Unfinished / Black Bolts

- These bolts are made from MILD steel rods with square or hexagonal head. The shank is left unfinished i.e. rough as rolled.
- In structural elements to be connected holes are made larger than nominal diameter of bolts.
- As shank of black bolts are unfinished, the bolts may not establish contact with structural member at entire zone of contact surface.
- Joints remain quite loose resulting into large deflections.
- These bolts are used for light structures under static loads such as trusses, bracings and also for temporary connections required during erections.
- It is not recommended for connection subjected to impact, fatigue or dynamic loading.
- Bolt of property class 4.6 means, ultimate strength is 400 N/mm^2 and yield strength is $400 \times 0.6 = 240 \text{ N/mm}^2$
- If a bolt is designated as M16, M20, M24, M30, it means shank dia of 16 mm, 20 mm, 24 mm, 30 mm respectively.

2.3.2 Finished/Turned Bolts

- These bolts are also made from mild steel, but they are formed from hexagonal rods, which are finished by turning to circular shape.
- Tolerance available for fitting is quite small (0.15 mm to 0.5 mm).
- It needs special methods to align bolt holes before bolting.
- As connection is more tight, it results in to much better bearing contact between the bolts and holes. These bolts are used in special jobs like connecting machine parts subjected to dynamic loadings.

2.3.3 High Strength Friction Grip (HSFG) Bolts (High Strength Bolt)

- Made from bars of medium carbon steel.
- Normally class 8.8 and 10.9 are commonly used
- Less ductile than black bolts
- Material of the bolt does not have well-defined yield point. In stead of yield stress, proof load is used
- As per IS 800 : 2007 proof load is taken as $0.7 \times$ ultimate tensile stress of bolt
- M16. M20. M24. M30, are generally used
- designated like 8.8S, 10.9S, where, S denotes high strength bolt,
- Percentage elongation of these bolts at failure is approx 12%

- Special techniques are used for tightening the nuts to induce specified initial tension in the bolts, which caused sufficient friction between the flaying forces.
- These bolts with induced initial tension as called high strength friction grip (HSFG) bolts.
- Due to friction, the sleep in the joint is eliminated hence, connection in this case is called nonslip connection or friction type connections.

Note : Black bolt connection → bearing type connection

- Induced initial tension in bolt is called proof-load
- Coefficient of friction is called slip factor
- HSFG bolts provide rigid connection as no slip is involved.
- As forces are transferred by friction only, bolt is not subjected to shear or bearing
- Due to high strength smaller number of bolts are used and hence material requirement of joints reduces
- Since under working load, bearing does not come into play, size of holes can be larger for case of erection and to take care of lack of fit.
- Since the load causing fatigue will be within proof load, the nuts are prevented from loosening and hence fatigue strength of joint will be greater and better than welded and riveted joints.
- Since loads are transferred by friction, there is not stress concentration in the holes.

2.4 CLASSIFICATION OF BOLTS BASED ON METHOD OF LOAD TRANSFER

On the basis of load transfer in the connection, bolts may be classified as :

- Bearing type
- Friction grip type

Unfinished (black) bolts and finished (turned) bolts are bearing type since they transfer shear force from one member to other member by bearing, whereas HSFG bolts belongs to friction grip type since they transfer shear by friction.

2.5 TERMINOLOGY USED IN BOLTED CONNECTION

2.5.1 Pitch of the Bolts (p)

It is the centre to centre spacing of bolts in a row, measured in the direction of load.

2.5.2 Gauge (g)

It is the distance between the two consecutive bolts of adjacent rows and is measured at right angle to the direction of load.

2.5.3 Staggered Pitch (p_s)

It is the centre to centre distance of staggered bolts measured in the direction of load.

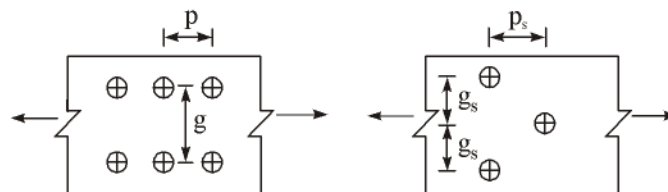

2.5.4 Diameter of Bolt Hole

Diameter of bolt hole is larger than the nominal diameter (shank diameter) of the bolt to facilitate erection and to allow for inaccuracies in fabrication.

Holes are

standard clearance hole → normal

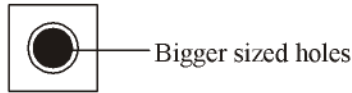

oversized holes (i.e. holes of size larger than standard clearance hole) → used in slip resistant connection.

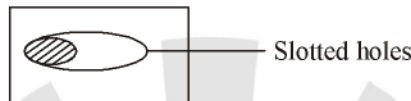

Short and long slot → used in slip resistant connection

Following table gives the diameter of holes for bolts.

2.5.5 Clearances for Fastener (Bolt) Holes

Nominal Size of Fastener, d mm	Size of the hole = Nominal diameter of the fastener + clearances mm			
	Standard clearance in diameter and width of slot	Over size clearance in diameter	Clearance in the length of the slot	
			Short slot	Long slot
2.	3.	4.	5.	6.
12-14	1.0	3.0	4.0	2.5 d
16-12	2.0	4.0	6.0	2.5 d
24	2.0	6.0	8.0	2.5 d
Larger than 24	3.0	8.0	10.0	2.5 d

From the above table :

Diameter of Normal Bolt Holes are :

Nominal size of Bolts in mm	12	14	16	20	22	24	30	36
Diameter of Bolt hole in mm	13	15	18	22	24	26	33	39

2.5.6 Clearances for Fastener (Bolt) Holes

Gross diameter of rivet = nominal diameter (ϕ) + 1.5 if $\phi \leq 25$ mm

Gross diameter of rivet = nominal diameter (ϕ) + 2.0 if $\phi > 25$ mm

If nominal diameter of rivet is not given then from Unwin's formula

$$\phi = 6.01 \sqrt{t}$$

2.5.7 Area of Bolt at Root (A_{nb})

Area of Bolt at root of the thread is less than that at shank of the Bolt. It is taken approximately equal to 0.78 times the shank area i.e.

$$A_{nb} = 0.78 \times A_{sb}$$

where

A_{sb} = Area of bolt at shank

$$= \frac{\pi}{4} d^2$$

d = Nominal diameter of Bolt (Shank diameter)

A_{nb} = Area of bolt at root

2.6 IS 800-2007 SPECIFICATIONS FOR SPACING AND EDGE DISTANCES OF BOLT HOLE

Pitch 'p' shall not be less than 2.5 d, where d is the nominal diameter of bolt.

Pitch 'p' shall not be more than

- 16 t or 200 mm, whichever is less, in case of tension members.
- 12 t or 200 mm, whichever is less, in case of compression members where t is the thickness of thinner plate.
- In case of staggered pitch, pitch may be increased by 50 percent of values specified above provided gauge distance is less than 75 mm.
- In case of compression member where forces are transferred through butting faces, i.e., (butt joints), maximum pitch is to be restricted to 4.5 d for a distance of 1.5 times the width of plate from the butting surface. (Refer Figure Below).

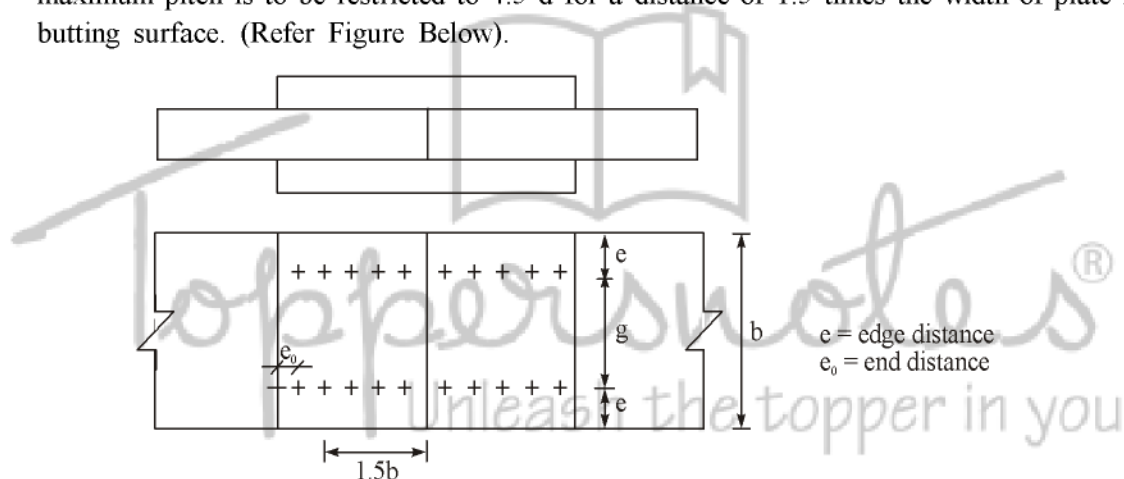

- The gauge length 'g' should not be more than 100 + 4t or 200 mm whichever is less in compression and tension member where t is the thickness of thinner outside plate.

Minimum edge and end distance shall not be

- Less than 1.7 × hole diameter in case of sheared or hand flame out edges.
- Less than 1.5 × hole diameter in case of rolled, machine flame cut, sawn and planed edges.

Maximum edge distance (e) should not exceed

- 12 t ϵ , where $\epsilon = \sqrt{\frac{250}{f_y}}$ and t is the thickness of thinner outer plate. This recommendation does not apply to fasteners interconnecting the components of back to back tension members.
- Where the members are exposed to corrosive environment max edge distance $\geq 40 \text{ mm} + 4 t$, where t is the thickness of thinner connected plate.

Apart from the required bolt from the consideration of design forces, additional bolts called tacking fasteners should be provided as specified below.

- Tacking rivets should be provided.
 - At 32 t or 300 mm, whichever is less, if plates are not exposed to weather,
 - At 16 t or 200 mm, whichever is less, if plates are exposed to weather.

In case of a tension member made up of two flats or angles or tees or channels, tacking rivets are to be provided along the length to connect its components as specified below:

- Not exceeding 1000 mm, if it is tension member.
- Not exceeding 600 mm, if it is compression member.

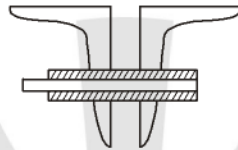

Countersunk heads

- $\alpha/2$ is neglected in calculating length of fastener in bearing
- for Fastener in tension having countersunk heads, tensile strength is reduced by 33.3% and no reduction in shear strength calculation.

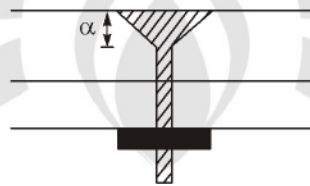

2.7 VARIOUS TYPES OF JOINTS

Types of joints may be grouped into the following two :

- Lap joint
- Butt joint

2.7.1 Lap Joint

It is the simplest type of joint. In this the plates to be connected overlap one another.

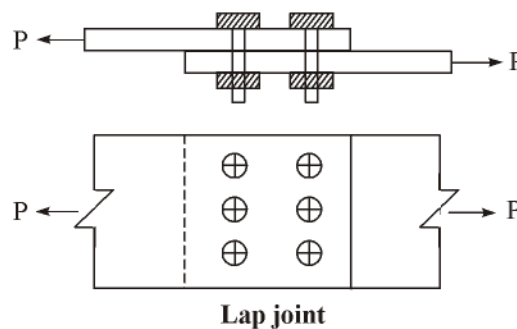

2.7.2 Butt Joint

In this type of connections, the two main plates butt against each other and the connection is made by providing a single cover plate connected to main plate or by double cover plates, one on either sides connected to the main plates.

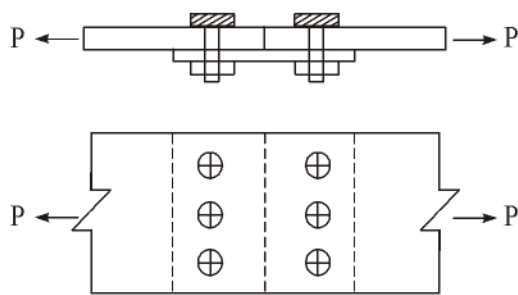

Single cover butt joint

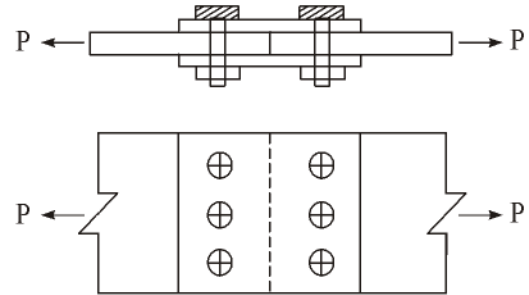

Double cover butt joint

2.8 TYPES OF ACTIONS ON FASTENERS

Depending upon the types of connections and loads bolts are subjected to the following types of actions:

- Only one plane subjected to shear (single shear).
- Two planes subjected to shear (double shear).
- Pure tension
- Pure moment
- Shear and moments in the plane of connection
- Shear and tension

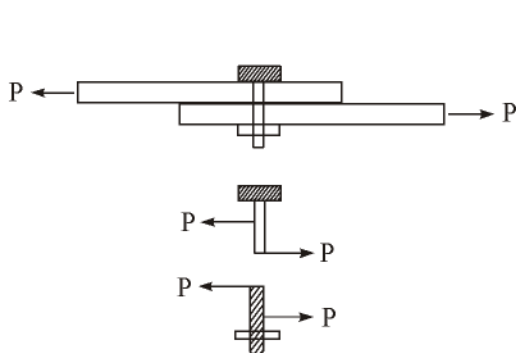

Only one plane subjected to shear

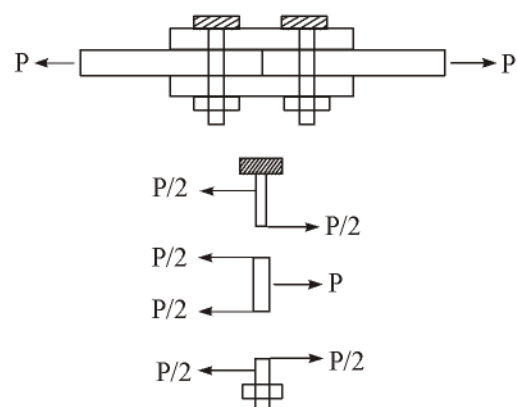

Bolt in double shear

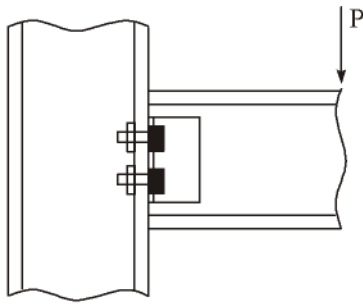

Bolts subjected to shear and tension

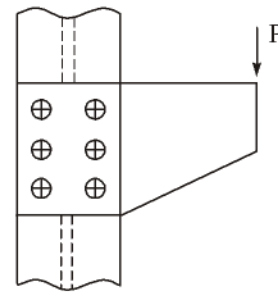

Bolts subjected to shear and moments (Torsional)

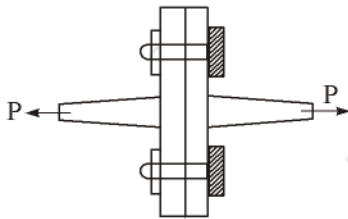

Bolt in direct tension

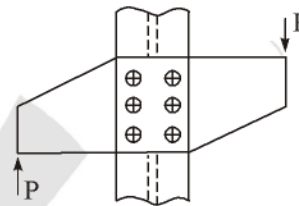

Bolts subjected to pure moments (Torsional)

2.9 ASSUMPTIONS MADE IN DESIGN OF BEARING BOLTS

The following assumptions are made in the design of bearing (finished or unfinished) bolted connections:

1. The friction between the plates is negligible.
 2. The shear is uniform over the cross-section of the bolt.
 3. The distribution of stress on the plates between the bolt holes is uniform.
 4. Bolts in a group subjected to direct loads share the load equally.
 5. Bending stresses developed in the bolts is neglected.
- Assumption 1 is questionable because friction exists between the plates as they are held tightly by bolts. But this assumption results on safer side in the design.
 - Actual stress distribution in the plate is not uniform. In working conditions, stresses are very high near bolt holes. But with increase in load the fibres near the hole start yielding and hence stresses at other parts start increasing. At failure the stress distribution is uniform and the ultimate load carrying capacity is given by the net area times the yield stress.
 - The fourth assumption is questionable. The bolts far away from centre of gravity of bolt groups are subject to more loads. In the ultimate stage all rivets have to fail, till then redistribution of load will be taking place. Hence the assumption is not completely wrong. IS 800-2007 permits this assumption for short joints (distance between first and the last bolt in the direction of load being less than $(15 \times d)$). For long, a reduction factor has been recommended for finding the strength of joint.

2.10 DESIGN STRENGTH OF PLATES

Plates in a joint made with bearing bolts may fail due to any one of the following :

- Shearing or bursting of the edge.
- Crushing of plates.
- Rupture of plates.