



**UKPSC – JE**

**Mechanical Engineers**

**Uttarakhand Public Service Commission (UKPSC)**

**Volume - 2**

**(Technical)**

**Theory of Machines & Machine Design**



# INDEX

S No.	Chapter Title	Page No.
1	Theory of Machine	1
2	Analysis of Planar Mechanism	54
3	Dynamic Analysis and Crank Mechanism	67
4	Gear Trains	71
5	Flywheels	83
6	Linear Vibrations Analysis	87
7	Introduction to Machine Design	106
8	Static Loading	109
9	Fatigue	113
10	Design of Joints	127
11	Clutches	172
12	Power Screw	180
13	Rolling & Sliding Contact Bearings	192
14	Gears	212
15	Brakes	230

# 1 CHAPTER

## Theory of Machine

### THEORY

#### 1. MACHANISM :

If a number of bodies assembled in such a way that the motion of one causes constrained and predictable motion to others, it is known as 'Mechanism'.

It transmit or modify a motion e.g. slider-crank mechanism, type writer, spring toys.

#### ⇒ Machine:

A machine is a machanism or a combination of mechanism which, apart from imparting motion to the part, also transmits and modifies the available mechanical energy into some kind of desired work.

#### ⇒ Type of Constrained Motion

Completely constrained motion

When motion between two elements of a pair is in a definite (*single*) direction irrespective of the direction of force applied. It is known as completely constrained motion.

Succesfully constrained motion

When motion between two element of pair is *possible* in *more than one* direction but is made to have motion *only in one* direction by using some *external* means, it is called succesfully constrained motion e.g.

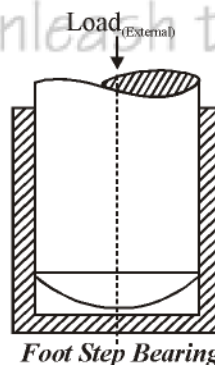

A piston in a cylinder of an internal combustion engine is made to have only reciprocating motion due to constrain of the piston pin (external), cam and follower, shaft in foot step bearing.

Incompletely constrained motion:

When the motion between the elements of a pair is possible in *more than one direction* and depends upon the *direction of force applied*, it is known as incompletely constrained motion e.g. cylindrical shaft in round bearing.

## Rigid, Resistant Body

### Rigid body:

It does not suffer any distortion, under the action of force.

### Resistant body:

Those body which are rigid for the purpose they have to serve for e.g. belt drive, where belt is rigid when subjected to tensile forces. Resistant bodies transmit the required forces with negligible deformation.

### Link

A link is defined as a member of mechanism, connecting other member and having motion relative to them.



## Classification of Kinematic Pair

According to nature of contact:

### ➤ Lower pair:

A pair of links having *surface or area* contact between the member. e.g. nut turning on a screw, shaft rotating in a bearing, all pair of slider-crank mechanism.

### ➤ Higher pair

When a pair has point or line contact between the links, it is known as higher pair. e.g. wheel rolling on a surface, cam and follower pair.

## According to Nature of Mechanical Constraint

### ➤ Closed pair

When the element of pair held *mechanically*, it is known as closed pair.

The contact between the two can be broken by only destruction of *at least one* of the member.

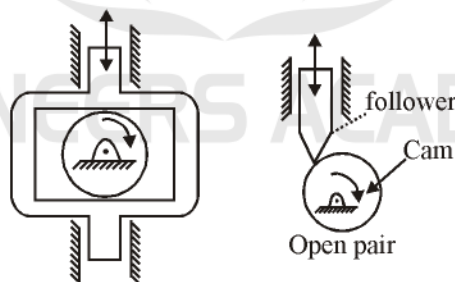

Point to remember:

### ➤ All lower pairs are closed pair.

### ➤ Open (unclosed pair)

When two links of a pair are in contact either due to force of gravity or some spring action.

e.g. cam follower.

According to Nature of Relative Motion

- Sliding pair  
If two links have sliding motion relative to each other, they form sliding pair e.g.  
A rectangular rod in a rectangular hole in a prism.
- Turning pair  
When one link has turning or revolving motion relative to the other, they constitute a turning or revolving pair e.g. circular shaft revolving in a bearing.
- Rolling pair  
when the link of pair have rolling motion relative to each other, they form a rolling pair, e.g.  
Rolling wheel on flat surface, ball and roller bearing.
- Screw pair (helical)  
If two mating link have turning as well as sliding motion between them form a screw pair e.g. lead screw, nut of lathe.
- Spherical pair  
When one link in the form of a sphere turns inside a fixed link, it is a spherical pair e.g. ball in socket.

### Type of Joints

There are three typer of joint.

- Binary joint (B)  
*If two* links are joined at the same connection.
- Ternary joint (T)  
if three link are joined at a connection, it is consider equivalent to two binary joint. Since fixing of any one link constitutes two binary joints.
- Quaternary joint (Q)  
If four links are joined at a connection. It is quaternary joint. It is equivalent to three binary joint.

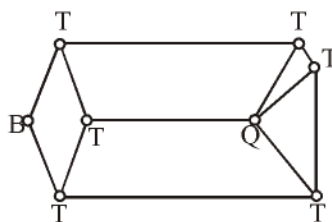

Point to remember:

- If n number of links are connected at a joint, it is equivalent to (n-1) binary joints.

### Degree of freedom

The connection of link with another imposes certain constrains on relative motion thus,

Degree of freedom = 6 – number of restraints

**Points to remember:**

- Number of restraints can never be zero (joint disconnected)
- Number of restraints can never be 6 (joint become rigid.)

**Degree of Freedom of Space Mechanism (3-D)**

$$F = 6(L - 1) - 5P_1 - 4P_2 - 3P_3 - 2P_4 - P_5$$

Here,

F = Degree of freedom (D.O.F.)

L = Total number of links in mechanism

P<sub>1</sub> = Number of pair having one D.O.F.

P<sub>2</sub> = Number of pair having two D.O.F, and so on.

**Degree of freedom of plane (2D) mechanism (Grueble Criterion)**

$$F = 3(L - 1) - 2P_1 - P_2$$

Here, L = Number of link in a mechanism

P<sub>1</sub> = Number of pair shaving one degree of freedom.

P<sub>2</sub> = Number of pair shaving two degree of freedom.

- Kutzbach's equation

$$F = 3(L - 1) - 2j - h$$

Here, L = Number of link

j = Number of binary joint

h = Number of higher joint

- Grubler's Equation

For those mechanism which have single degree of freedom and zero higher pair.

$$3l - 2j - 4 = 0$$

Here,

l = Number of links

j = Number of binary joints

- Degree of Freedom

F = 0 (Frame)

F < 0 (redundant frame), indeterminate structure

F > 0 (constrained/unconstrained frame)

Point to remember:

- All mechanism have minimum 4 number of link.

**Kinematic Chain**

When all the links are connected in such a way that first link is jointed with the last link, then the structure formed is known as closed chain. The closed chain will be a kinematic chain when the relative motion between the link is either completely constrained or successfully constrained.

- Condition for a kinematic chain

There are two conditions and both the conditions are equivalent.

- Relation between the number of links and number of pair.

$$l = 2P - 4$$

where,  $l$  = Number of link

$P$  = Number of pair

- Relation between number of binary joints and number of links

$$2J = 3l - 4$$

where,  $J$  = Number of binary joint.

$l$  = Number of link

- (i) If L.H.S. > R.H.S.

Locked chain or frame or structure

- (ii) If L.H.S. = R.H.S

Kinematic chain (constrained chain)

- (iii) If L.H.S. < R.H.S

unconstrained chain

Redundant chain

It does not allow any motion of a link relative to other.

#### Frame/Structure

If one of the link of redundant chain is fixed. It is known as structure or a locked system.

- ⇒ Points to remember:

No relative motion

Capable of transmitting force only.

Power/energy can not be transmitted.

Degree of freedom of *structure* is zero.

Degree of freedom of super structure is less than zero.

#### Simple Mechanism

All the mechanism having 4-links are simple mechanism and the mechanism having more than 4 links are compound mechanism.

There are three different simple mechanisms.

- Four bar mechanism/Quadric cycle chain.

It consists of four link and four turning pair.

- Slider crank mechanism

It consists four link, three turning pair and one sliding pair.

- Double slider crank mechanism.

It consists four link, two turning pair and two sliding pair.

## Four-Bar Mechanism

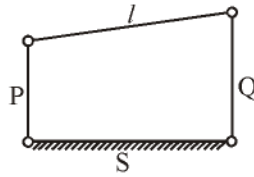

➤ Grashof's law

$$S + l \leq P + Q$$

Here,

$S$  = Shortest link length

$l$  = Longest link length

$P, Q$  = Adjacent link length to shortest link.

Case-I:

If  $S + l < P + Q$

- $S$  is fixed – Double crank mechanism.
- $P$  or  $Q$  fixed – Crank rocker mechanism
- $l$  is fixed – Rocker-rocker mechanism

Case-II:

If  $S + l = P + Q$

- All link have different length then same as case-1.
- Parallelogram linkage-crank-crank mechanism.  
i.e.  $S = P, l = Q$

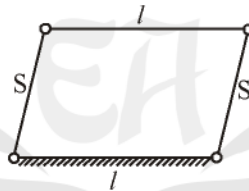

$S$  is fixed – Double crank mechanism.

$l$  is fixed – Double crank mechanism.

Deltoid linkage

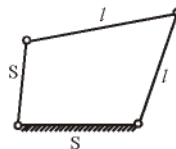

(a)  $S$  is fixed – Crank-crank mechanism

(b)  $l$  is fixed – Crank-rocker mechanism.

Case-III:

$$s + l > P + Q$$

Grashof's law is not satisfied and it will give non grashof's rocker-rocker mechanism.

### Inversion of 4-Bar Mechanism

Coupling rod of locomotive –	Crank-crank mechanism
Beam engine –	Crank-rocker mechanism
Watt's indicator –	Rocker-rocker mechanism

### Points to remember:

Approximate straight line mechanism are watts indicator, modified Scott-russel mechanism (Grass Hopper mechanism). The tchebicheff straight line mechanism.

Exact straight line mechanism are Peculiar mechanism, Hart mechanism, Scott-russel mechanism.

### Inversion of Slider-Crank Mechanism

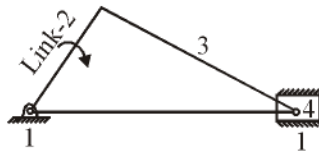

First inversion-link 1 is fixed.

Reciprocating engine/compressor.

Second inversion-link 2 is fixed (Crank)

Whitworth quick return mechanism, rotary (radial) engine.

Third inversion-link 3 is fixed (Connecting Rod)

Crank and slotted lever mechanism, oscillating cylinder mechanism.

Fourth inversion-link 4 is fixed (Slider)

Hand pump, bull engine.

### Inversion of Double Slider Crank Mechanism

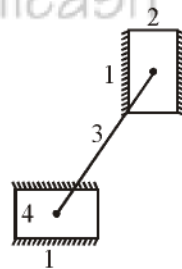

First inversion-link 1 is fixed

Elliptical trammel.

Second inversion-slider 2 is fixed.

Scotch yoke mechanism.

Third inversion-link 3 is fixed

Oldham coupling.

## Mechanical Advantage

$$\text{M.A.} = \frac{\text{Output force / torque}}{\text{Input force / torque}}$$

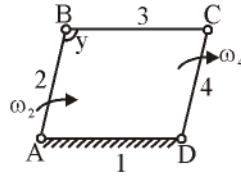

Power input = Power output

$$T_2 \omega_2 = T_4 \omega_4$$

$$\text{M.A.} = \frac{T_4}{T_2} = \frac{\omega_2}{\omega_4}$$

Points to remember:

If  $\gamma$  is equal to  $0^\circ$  or  $180^\circ$ ,  $\omega_4$  become zero thus mechanical advantage will be infinity.

Extreme position of linkage is known as toggle position.

## 2. Velocity Analysis

Velocity in machines can be determined by either analytically or graphically. This chapter deals with graphical analysis.

### Velocity Analysis

Let

$V_{ao}$  = Velocity of A relative to O

$V_{ba}$  = Velocity of B relative to A

$V_{bo}$  = Velocity of B relative to O

$V_{bo} = V_{ba} + V_{ao}$

Velocity of A relative to O =  $\frac{\text{Arc } AA'}{\delta t}$

$$V_{ao} = \frac{r \cdot \delta \theta}{\delta t} = r \frac{d\theta}{dt} = r\omega$$

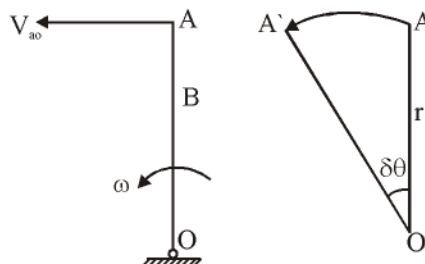

as  $\delta t \rightarrow 0$ ,  $AA'$  will be perpendicular to  $OA$ , Thus the velocity of A is  $r\omega$  and is perpendicular to  $OA$ .

**Points to remember:**

The velocity of any point relative to any other point on a fixed link is always zero.

The velocity of an intermediate point on any of links can be found easily by dividing the corresponding velocity vector in the same ratio as the point divides link.

The angular velocity of a link about one extremity is the same as the angular velocity about the other.

**Velocity of Rubbing**

The velocity of rubbing of the two surface will depend upon the angular velocity of a link, relative to the other.

If pin at A

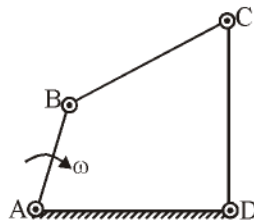

Pin at A joins links AD and AB. AD being fixed the velocity of rubbing will depend only upon angular velocity of AB.

∴ Velocity of rubbing

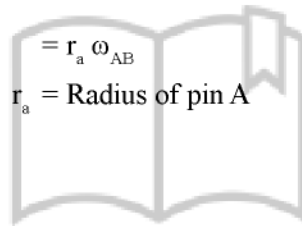

Here,

Pin at D

Velocity of rubbing =  $r_d \cdot \omega_{cd}$

Pin at B

Both link AB and BC is moving

$\omega_{ab} = \omega = \text{clockwise}$

$\omega_{bc} = \omega = \text{anticlockwise}$

∴ Velocity of rubbing =  $r_b (\omega_{ab} + \omega_{bc})$

Pin at C

Velocity of rubbing =  $r_c (\omega_{bc} + \omega_{dc})$

**Theory of Instantaneous Centre**

Instantaneous centre of rotation or virtual centre.

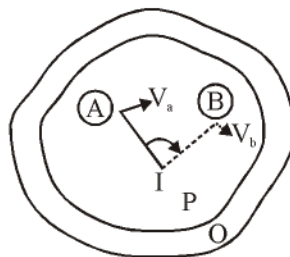

Let a plane body 'P' having non-linear motion relative to another plane body Q. At any instant, the linear velocities of the point 'A' and 'B' on the body 'P' are 'V<sub>a</sub>' and 'V<sub>b</sub>' respectively.

If a line is drawn perpendicular to the direction of  $V_a$  at 'A', the body can be imagined to rotate about some point on this line. Similarly for point B. If the intersection of the two lines is at 'I', the body 'P' will be rotating about I at the instant.

This point 'I' is known as instantaneous centre of velocity.

**Point to remember:**

If the direction  $V_a$  and  $V_b$  are parallel the I-centre of body lies at infinity.

**Centrode:**

As we know, in general the position of instantaneous centre changes throughout the whole motion. The locus of all these instantaneous centre for a particular link is known as 'Centrode'. It is a *curve*.

**Axode:**

The line passing through instantaneous centre and perpendicular to the plane of motion is known as instantaneous axis. The locus of instantaneous axis for a link during the whole motion is known as 'Axode'. It is a *surface*.

**Instantaneous Centre in Different Situation**

If two links are attached with a turning pair, the instantaneous centre of such a pair will be at *pin joint*.

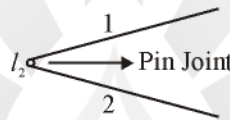

Rolling of a sphere on a plane.

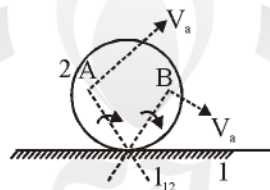

Instantaneous centre will be at point of contact.

Object sliding on a plane surface.

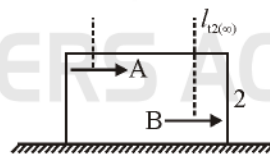

The location of  $I_{12}$  will be at infinity but in a direction perpendicular to the *sliding surface*.

Object sliding on a *curved* surface.

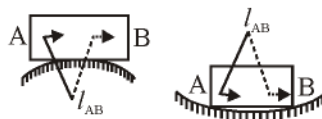

Instantaneous centre will be at the *centre* of curvature of curved surface.

### Number of Instantaneous Centre

$$l = \frac{n(n-1)}{2}$$

Here,

n = Number of link

### Crank and Slotted Lever Mechanism

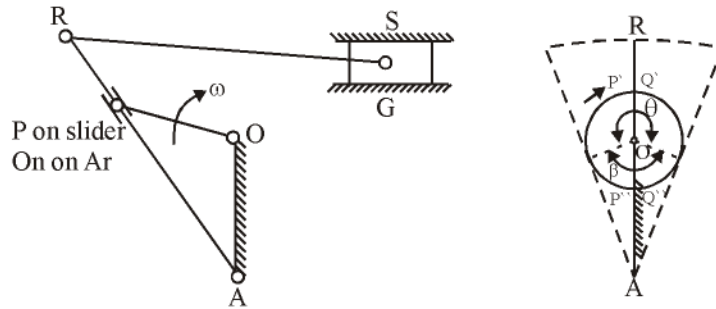

Let,

r = length of crank (= OP)

l = Length of slotted lever (=AR)

C = Distance between fixed centres (=AO)

$\omega$  = angular velocity of crank

Thus during cutting stroke

$$\frac{(V_s)_{\max} \text{ (cutting)}}{(V_s)_{\max} \text{ (return)}} = \frac{c-r}{c+r}, \quad \frac{\text{Time of cutting}}{\text{Time of return}} = \frac{\theta}{\beta}$$

### Kennedy's Theorem

For the three bodies having the continuous relative motion there all instantaneous centres lies on the same line.

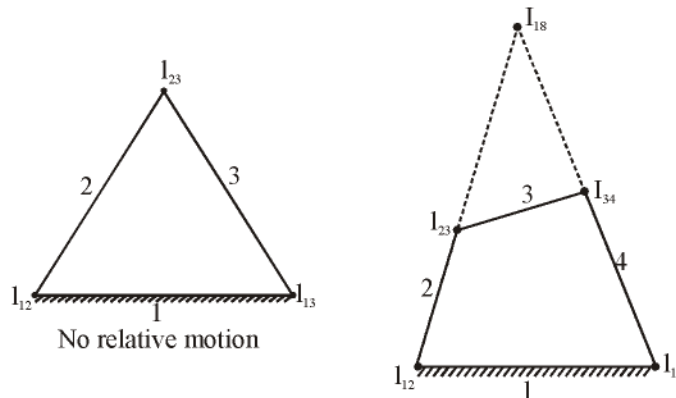

### Angular Velocity Ratio Theorem

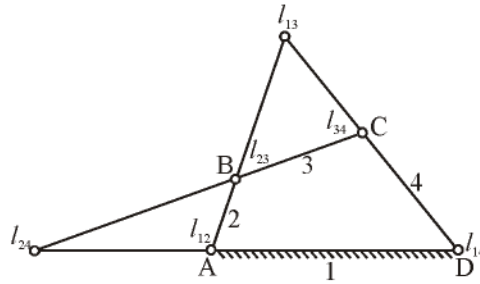

It is used to find angular velocity of a link if angular velocity of another link is known.

The angular velocity ratio of two links relative to third link is inversely proportional to the distances of their common I-centre from their respective centre of rotation.

$$\frac{\omega_4}{\omega_2} = \frac{I_{24} - I_{12}}{I_{24} - I_{14}}$$

Angular velocity ratio is positive when the common instantaneous center falls outside the other two centers & negative when it falls between them.

### 3. Acceleration Analysis

The rate of change of velocity with respect to time is known as acceleration and it acts in the direction of the change in velocity.

#### Tangential and Centripetal Acceleration

The rate of change of velocity in the tangential direction of the motion is known as tangential acceleration.

$$a_t = \frac{dv}{dt}$$

The rate of change of velocity towards the centre of rotation is known as centripetal or radial acceleration.

$$a_c = \frac{v^2}{r}$$

#### Points to remember:

The tangential component of acceleration occurs due to the angular acceleration of link.

the acceleration of intermediate points on the links can be obtained by dividing the acceleration vectors in the same ratio as the points divide the links.

#### Coriolis Acceleration Component

Coriolis Acceleration Component

Let,

$\omega$  = Angular velocity of the link

$\alpha$  = Angular acceleration of the link

$v$  = Linear velocity of the slide of the link

$f$  = Linear acceleration of the slider on the link

$r$  = Radial distance of point P on the slider.

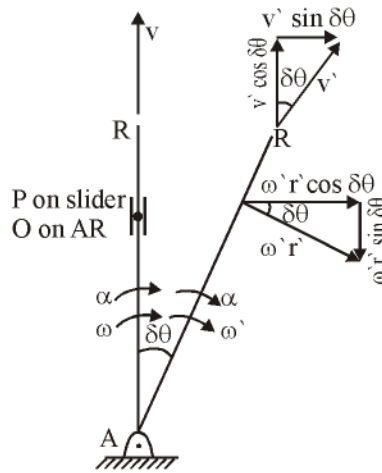

Acceleration of P along AR =

Acceleration of slider – Centrifugal acceleration

$$= f - \omega^2 r$$

Acceleration of P perpendicular to AR

$$= 2 \omega v + \text{Tangential acceleration}$$

$$= 2 \omega v + r \alpha.$$

### Points to Remember:

The component  $2 \omega v$  is known as the Coriolis acceleration component.

The direction of the coriolis acceleration component is obtained by rotating the radial velocity vector 'v' through  $90^\circ$  in the direction of rotation of the link.

### Klein's Construction

In Klein's construction, the velocity and the acceleration diagrams are made on the configuration diagram itself. The line that represents the crank in the configuration diagram also represents the velocity and acceleration of its moving end in the velocity and acceleration diagram respectively.

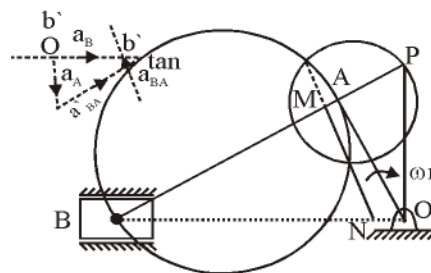

$$\frac{a_B}{ON} = \frac{a_{B_A}}{AM} = \frac{a_A}{OA} = \frac{a_{B_A}^{\tan}}{NM} = \omega^2$$

OAP – Velocity diagram

OAMN – Acceleration diagram.

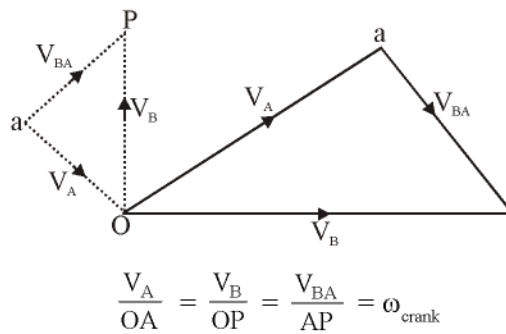

### Some Other Important Points

Acceleration images are helpful to find the accelerations of offset points of the links. The acceleration image of link is obtained in the same manner as a velocity image.

Acceleration of a point on a link relative to a coincident point on a moving link is the sum of absolute acceleration of the coincident point, acceleration of the point relative to coincident point and the Coriolis acceleration.

## 4. CAM

A cam is mechanical member used to impart desired motion to a follower by direct contact. The cam may be rotating or reciprocating whereas the follower may be rotating, reciprocating or oscillating.

It is used in automatic machine, IC engine, machine tools, printing control mechanism.

### Element of Cam

A driver member known as the cam

A driven member called the follower

A frame which supports the cam and guides the follower.

### Point of remember:

A cam and follower combination belong to the category of higher pair.

### Types of Cam

According to Shape

Wedge and flat cams

A wedge cam has a translational motion, the follower can either translate or oscillate.

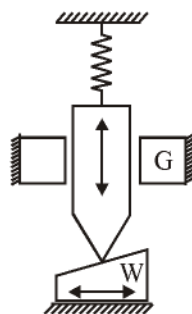

### Radial or Disc Cams

A cam in which the follower moves radially from the centre of rotation of the cam is known as a radial or disc cam.

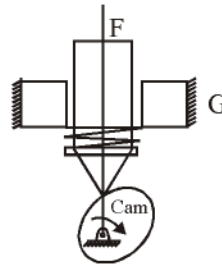

### Spiral cams

A spiral cam is a face cam in which a groove is cut in the form of a spiral. It is used in computer.

### Cylindrical cams

In a cylindrical cam, a cylinder which has a circumferential contour cut in surface, rotates about its axis. It is also known as barrel or drum cams.

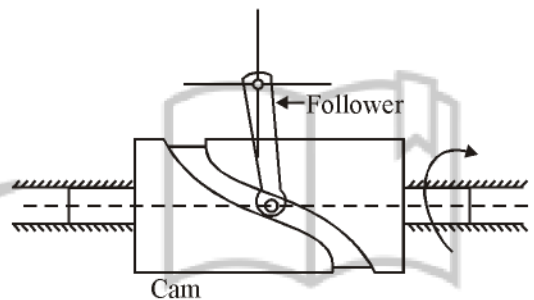

### Conjugate cams

It is a double disc cam and preferred when the requirements are low wear, low noise, better control of the follower, high speed, high dynamic loads etc.

### Globoidal cams

It has two types of surface i.e. convex or concave. It is used when moderate speed and the angle of oscillation of the follower is large.

### According to follower movement

#### Rise-Return-Rise (RRR)

In this there is alternate rise and return of the follower with no period of dwells. The follower has a linear or an angular displacement.

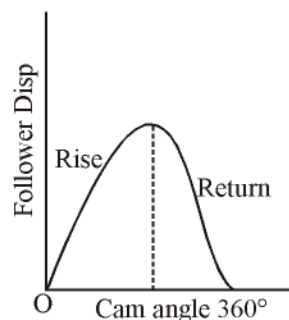

### Dwell-Rise-Return Dwell (D-R-R-D-S)

In this cam, there is rise and return of the follower after a dwell.

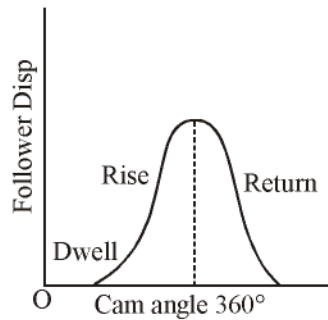

### Dwell-Rise-Dwell-Return-Dwell (D-R-D-R-D)

The dwelling of the cam is followed by rise and dwell and subsequently by return and dwell. In case the return of the follower is by a fall, the motion may be known as Dwell-Rise-Dwell (DRD)

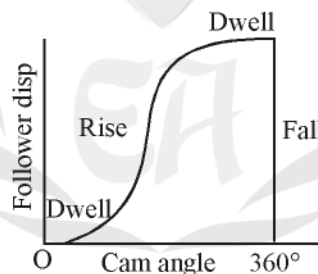
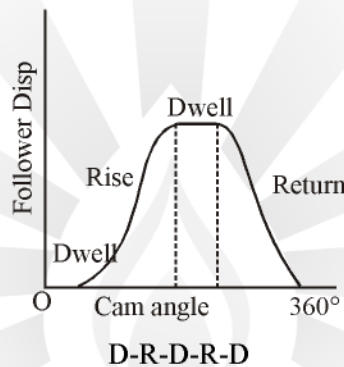

### Type of Follower

According to shape

#### Knife-edge follower:

Its use is limited as it produces a great wear of the surface at the point of contact.

#### Roller follower:

At low speeds, the follower has a pure rolling action, but at high speeds, some sliding also occurs.

#### Point to remember:

In case of steep rise roller follower is not preferred.

**Mushroom follower:**

It does not pose the problem of jamming the cam.

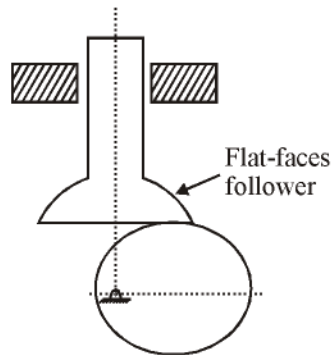

**According to movement**

➤ **Reciprocating follower:**

In this type, as the cam rotates the follower reciprocates or translates in the guides.

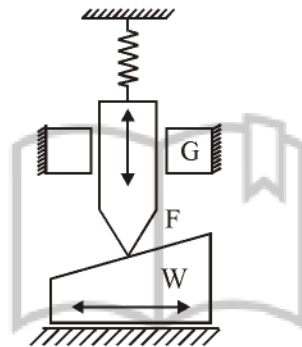

**Oscillating Follower:**

The follower is pivoted at a suitable point on the frame and oscillates as the cam makes the rotary motion.

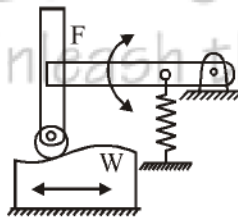

**According to location of line of movement**

➤ **Radial Follower:**

The follower is known as a radial follower if the line of movement of the follower passes through the centre of rotation of the cam.

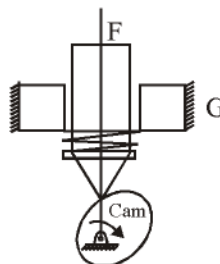

### Offset Follower:

If the line of movement of the roller follower is offset from the centre of rotation of the cam, the follower is known as an offset follower.

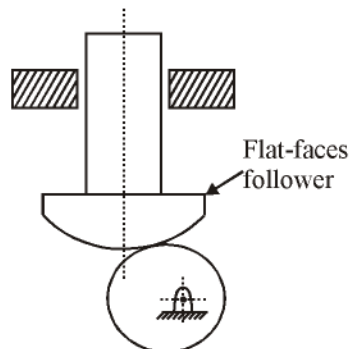

### Terminology of Cam

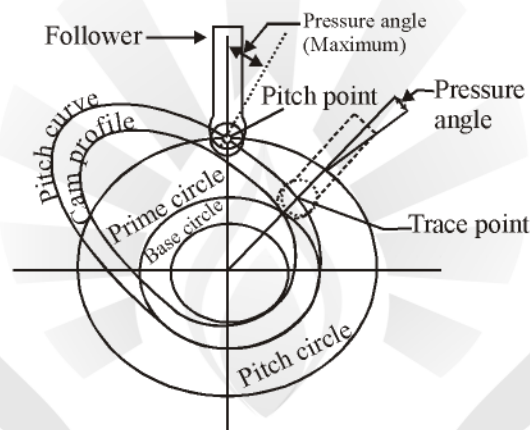

### Base circle

It is the smallest circle tangent to the cam profile drawn from the centre of rotation of a radial cam.

**Pressure angle:** The pressure angle, representing the steepness of the cam profile, is the angle between the normal to the pitch curve at a point and the direction of the follower motion. It varies in magnitude at all instants of the follower motion. A high value of maximum pressure angle is not desired as it might jam the follower in the bearing.

**Pitch point:** It is the point on pitch curve at which the pressure angle is maximum.

**Pitch circle:** It is the circle passing through the pitch point and concentric with the base circle.

**Angle of Ascent ( $\phi_a$ ):** It is the angle through which the cam turns during the time the follower rises.

**Angle of dwell ( $\delta$ ):** Angle of dwell is the angle through which the cam turns while the follower remains stationary at the highest or lowest position.

**Angle of Decent ( $\phi_d$ ):** It is the angle through which the cam turns during the time the follower returns to the initial position.

**Angle of Action:** It is the total angle moved by cam during the time, between the beginning of rise and the end of return of the follower.