



# RRRB - JE

←————→

# ELECTRONICS

## Railway Recruitment Board

Volume - 4

Microprocessor and Microcontroller



# CONTENTS

S.No.	Topic	Page No.
1.	Microprocessor and Microcontroller .....	01 – 07
	Practice Sheet .....	08 – 12
2.	Microprocessor 8085 .....	13 – 23
	Practice Sheet .....	24 – 25
3.	Instruction Set of 8085 .....	26 – 68
	Practice Sheet .....	69 – 93
4.	Interrupts of 8085 .....	94 – 103
	Practice Sheet .....	104 – 108
5.	Programming with 8085 .....	109 – 166
6.	Programmable Peripheral Devices .....	167 – 191
	Practice Sheet .....	192 – 203
7.	Microprocessor 8086 .....	204 – 217
	Practice Sheet .....	218 – 223

# Microprocessor and Microcontroller

## THEORY

### 1. INTRODUCTION OF MICROPROCESSOR

Microprocessor is one of the most important components of a digital computer. It can be viewed as a programmable logic device that can be used to control processes or to turn on/off devices. Simultaneously, it can be viewed as a data processing unit or a computing unit of a computer.

#### 1.1 DEFINITION

Microprocessor is the controlling unit or CPU of a micro-computer, fabricated on a very small chip capable of performing ALU operations and communicating with the external devices connected to it.

or

A microprocessor is a programmable integrated device that has computing and decision making capability similar to that of the Central Processing Unit (CPU) of a computer.

### 2. MICROPROCESSOR AS A CPU (MPU)

Generally, a basic computer has the four components/units :

- (1) Input Unit
- (2) Output Unit
- (3) Memory Unit
- (4) Central Processing Unit

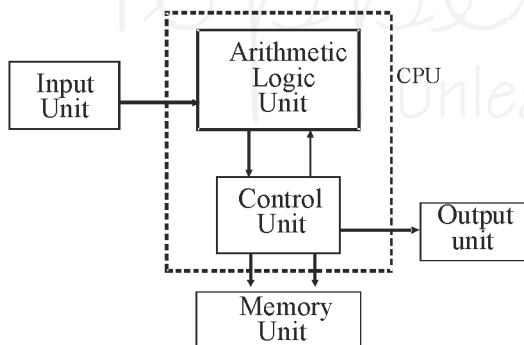

*Basic Block Diagram of Computer*

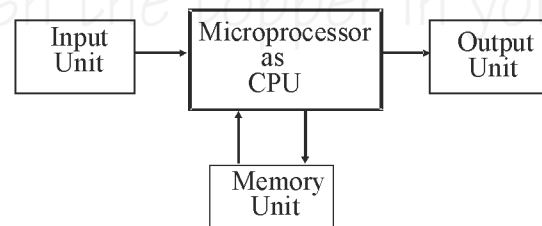

*Block Diagram of microprocessor as a CPU or a Micro Computer*

## 2.1 INPUT UNIT :

The input unit consists of the devices which accept the data and instructions from the user and communicates it to the CPU.

*Various input devices are :* Keyboard, mouse, Joystick, trackball etc.

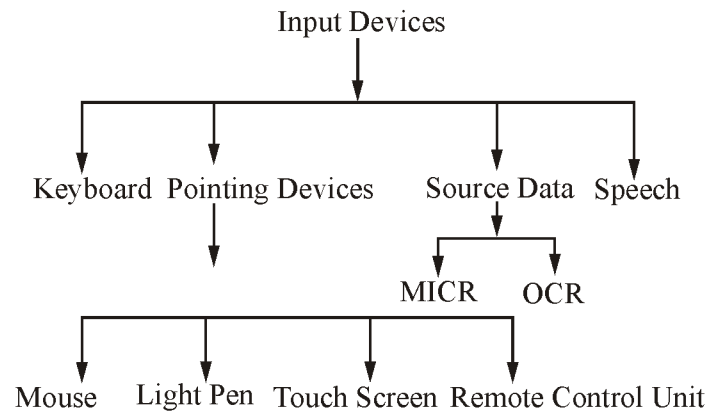

## 2.2 OUTPUT UNIT :

It provides the result of the various operations performed by the CPU to the user.

*Various output devices are :* Printer, Monitor, Loudspeaker etc.

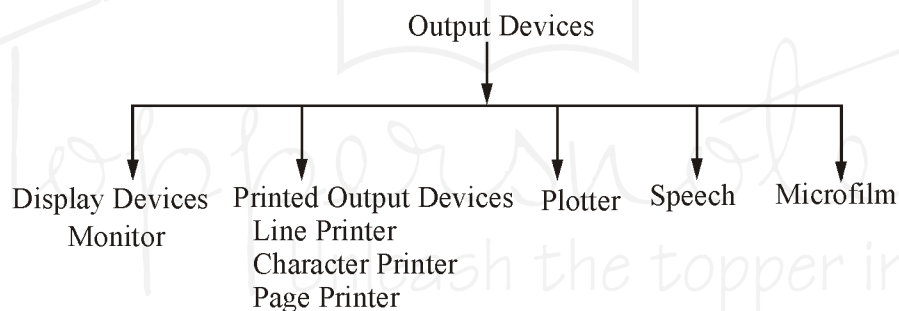

## 2.3 CENTRAL PROCESSING UNIT (CPU) :

It fetches the instruction and data from the peripheral devices and performs all the arithmetic operations, takes logical decision and control the operations of all other units.

CPU is considered to be heart and nerve centre of computer

*Sub blocks of the central processing unit are :*

- (a) Arithmetic & Logic Unit (ALU)
- (b) Timing & Control Unit (CU)
- (c) Registers

## 2.4 ARITHMETIC AND LOGIC UNIT (ALU) :

This unit performs all the logical and arithmetic operations.

*Various arithmetic operations are :* additions, subtraction, increment and decrement etc.

*Various Logical operation are :* AND, OR, NOT, XOR, etc.

## 2.5 TIMING AND CONTROL UNIT (CU) :

This unit controls the entire operations being performed by the system. It controls the operation of ALU, input/output devices and memory unit. This unit interprets the instructions and generates various timing and control signals.

## 2.6 REGISTERS :

A register is a very small amount of very fast memory that is built into the CPU in order to store the current data and instructions which are being executed by the CPU.

## 2.7 MEMORY UNIT :

- (1) It stores the program statement and the data i.e., the information supplied from the input unit and also stores the final output.
- (2) Through a bi-directional bus, it is connected to the CPU,
- (3) CPU processes the information as taken from the memory and performs the operations in the ALU section.

Results are either transferred to the output unit or stored in the memory for later use by CPU

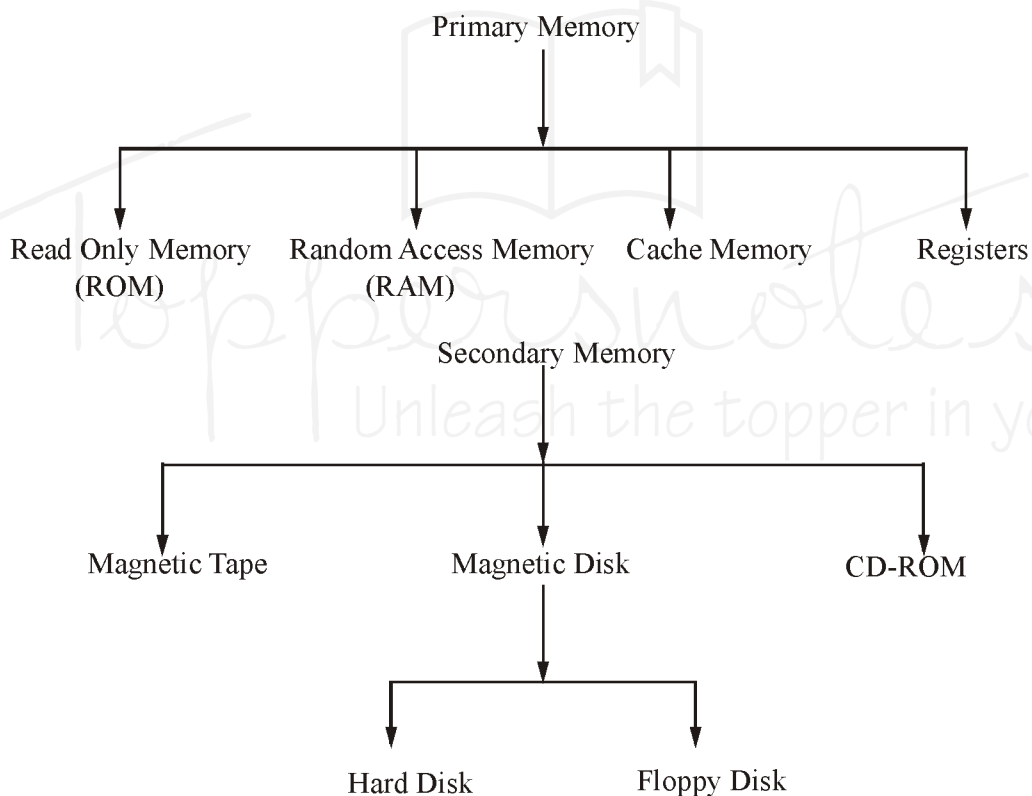

## 3. MICRO-COMPUTER

- (1) The microprocessor, embedded in a larger system, can be a stand alone unit controlling processes, or at can function as the CPU of a computer called microcomputer.
- (2) The block diagram of the microcomputer is similar to the computer except that the central processing unit of the micro computer is contained in a single IC called microprocessor.

(3) A microprocessor is a LSI (Large Scale Integration) IC that does almost all the functions of CPU.

*The basic function of microprocessor is :*

- (1) To fetch the instructions stored in the main memory
- (2) Identify the operations and the devices involved in it.
- (3) Generate control signals to determine when a given action is to take place.
- (4) A desktop computer, laptop, notebook, palmtop, etc., contain one microprocessor to act as a CPU and hence they come under the category of micro computer.

#### **4. MICROCONTROLLER**

A highly integrated chip that contains all the components such as CPU, RAM. Some form of ROM, input-output ports, A/D converter and timers is called Microcontroller or microcontroller unit (MCU).

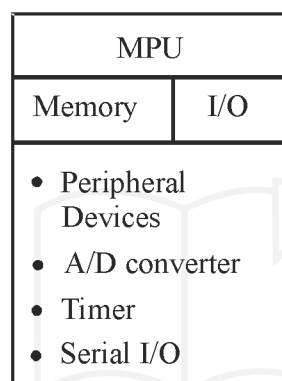

#### **5. MICROPROCESSOR CHARACTERISTICS**

##### **5.1 INSTRUCTION SET :**

- (1) A Microprocessor communicates and operates in the binary format 0 and 1 called bits.
- (2) Each microprocessor has a fixed set of instructions in the form of binary pattern called a machine language (platform dependent or machine specific language or low level language)
- (3) It is difficult for humans to communicate in the language of 0s and 1s, hence, binary instructions are given abbreviated names, called mnemonics, which form assembly language (platform dependent or machine specific language or low level language)



- (4) Assembler is a software. If translation task is performed manually, it is known as hand assembly.

*Note:* (1) *Compiler reads whole program at once from source code and produces object code that is executed by processor.*

- (2) *Interpreter. Reads instruction at a time from source code and produces its object code that is executed by processor before reading next instruction from source code.*

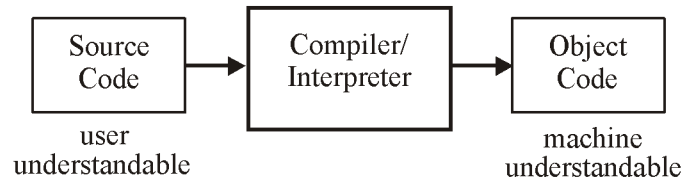

- **Faster Execution :**

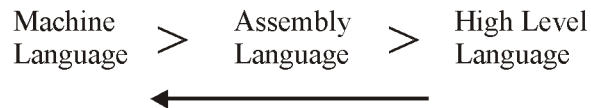

- **Memory :**

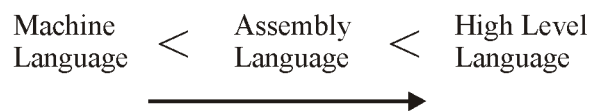

(Require Large memory to store)

- **Debugging :**

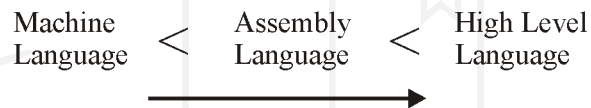

( Debugging or trouble shooting  
is faster i.e., to find error)

## 5.2 BAND WIDTH :

- (1) Gordon Moore, cofounder of Intel corporation, predicted that the number of transistors per integrated circuit would double every 18 months i.e., Moore's law.
- (2) Currently, processors are designed with 15 million transistors, that can address one Terabyte ( $1 \times 10^{12}$ ) of memory and can operate at 400 MHz to 1.5 GHz frequency.

## 5.3 CLOCK SPEED :

- (1) The clock speed determines how many operations per second the processor can perform.
- (2) Every computer contains an internal clock that regulates the rate at which instructions are executed and synchronizes the various computer components.
- (3) Expressed in megahertz (MHz) or gigahertz (GHz), faster the clock, more instructions CPU execute per second.
- (4) Microprocessor of personal computer have clock speeds of anywhere from 300 MHz to over 3.8 GHz.

## 5.4 WORD LENGTH :

- (1) It depends upon the width of internal data bus, registers, ALU etc.
- (2) Word length is defined as the number of bits the microprocessor recognizes and processes at a time.

## 6. CISC AND RISC

**CISC :-** CISC stands for complex instruction set architecture. The CISC approach attempts to minimize the number of instructions per program, instead of number of cycle per instruction.

**RISC :-** RISC stands for reduced instruction set architecture. The RISC approach attempts to reduce the cycle per instructions per program.

### 6.1 COMPARISON BETWEEN RISC AND CISC :

Parameter	RISC	CISC
Design	Simple	Complex
Design time	Short	Long
Speed	High	Low
Price	Cheap	Costly
	Single length instruction	Variable length instruction
	Simple operation	Complex operation
	Number of instruction is more	Number of instruction is less
	Tablet, Smartphone etc use RISC	Computer uses CISC

## 7. WORKING OF MICROPROCESSOR :

- (1) The instructions are stored sequentially in the memory.
- (2) The microprocessor fetches the first instruction from its memory sheet, decodes it and executes that instruction.
- (3) The sequence of fetch, decode and execute is continued until the microprocessor comes across an instruction to stop.
- (4) During the entire process, the microprocessor uses the system bus to fetch the binary instruction and data from the memory.
- (5) Uses register from the register section to store data temporarily and performs the computing function in the ALU section.
- (6) Using same bus lines, it sends out the result in binary format to the seven segment LED display.

## 8. MICROPROCESSOR APPLICATIONS

*The applications of microprocessors are given below:*

- (1) Toys Robots, remote-controlled cars, and hand games.
- (2) Simple Applications Microwave oven, telephone diallers, smart thermostats, shortwave scanners, and TV remote controls.
- (3) Complex Intelligent Product Controllers VCR control and programming, security systems, and lighting system controllers

- (4) Computer Peripherals Video Display, higher-speed printers, modems, plotters, and communication controllers.
- (5) Industrial Controllers Robotics, processing control, sequence control, and machine tool control.
- (6) Instruments Logic analysers, communication analyzers, disk drive testers, digital oscilloscopes, and smart voltmeters.
- (7) Communications Data, voice, mobile, electronic switching, and routing.
- (8) Automatic Test Equipment Automatic test equipment at all levels from development, fabrication, component testing assemble, PCB, module and system testing.
- (9) Electrical Power System Data acquisition, logging, protection, metering, control and processing, automatic control of generators voltage and fuel control of furnaces in a power plant.
- (10) Industrial Process Control Instrumentation, monitoring and control, data acquisition, logging and processing.
- (11) Household Appliances Cooking ovens, and washing machines.
- (12) Medical Electronics Quick patient check up, diagnosis, blood analysis, ECG, etc.
- (13) Database Management Word processing, database management and storing information.

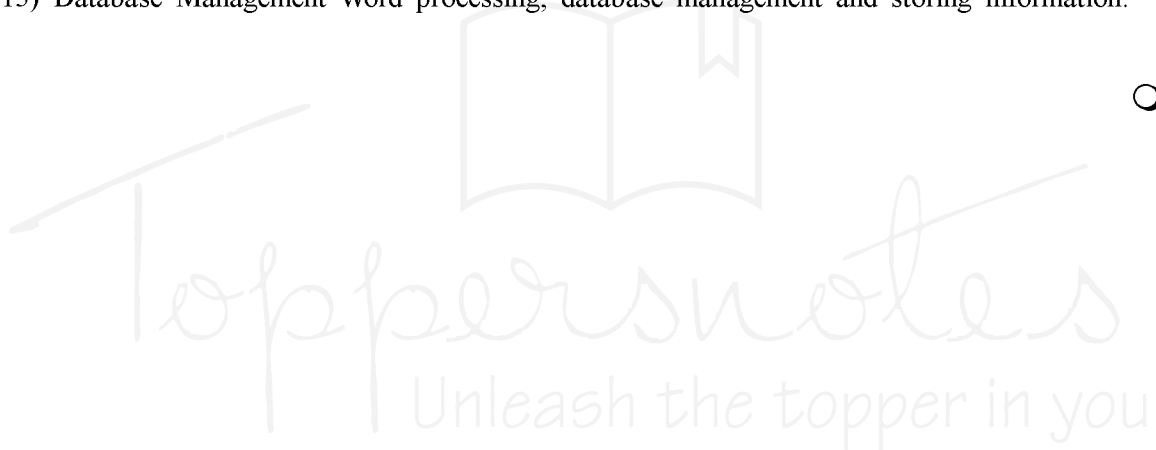

## PRACTICE SHEET

### OBJECTIVE QUESTIONS

- An 'Assembler' for a microprocessor is used for
  - Assembly of processors in a production line
  - Creation of new programmes using different modules
  - Translation of a program from assembly language to machine language
  - Translation of a higher level language into English text
- An I/O processor control the flow of information between
  - Cache memory and I/O devices
  - Main memory and I/O devices
  - Two I/O devices
  - Cache and main memories
- Assertion (A):** The auto increment and auto decrement modes are seldom found in modern processors.  
**Reason (R) :** Using two instructions instead of one, provides flexibility in implementing a pipeline.
  - Both A and R are true and R is the correct explanation of A
  - Both A and R are true but R is NOT the correct explanation of A
  - A is true but R is false
  - A is false but R is true
- Compared to a CISC Processor, a RISC processor has
  - Reduced cache memory
  - Reduced number of interrupts
  - Less number of instructions
  - Reduced address lines
- Assembler directives are required
  - Only in hand assembling
  - Only in machine assembling
  - In hand assembling as well as machine assembling
  - Only when there is an operating system
- Some system architects do not find RISC instruction repertoire to be cost-effective because it
  - Result in large increase in programme size
  - Result in complex structure of microcode
  - Has been observed that an average compiler does not employ more than a limited subset of an available instruction
  - result in complex decoding of opcode filled resulting in longer execution time
- .....is a primitive that can execute code . It contains an instruction pointer (= program counter) and sometimes has its own stack
  - Process
  - Task
  - Kernel
  - Thread
- The process of imitating one system with another so that the imitating systems accepts the same date, executes same programs and achieves same results as the imitated system is known as
  - Simulation
  - Modification
  - Translation
  - Emulation
- The computer program which converts statements written in high level language to object code is known as
  - Assembler
  - Operating system
  - Object-oriented software
  - None of the above

10. The digital multiplexer is basically a combi-national logic circuit to perform the operation
- (a) AND-AND      (b) OR-OR  
(c) AND-OR      (d) OR-AND
11. A microprocessor is ALU
- (a) And control unit on a single chip  
(b) And memory on a single chip  
(c) Register unit and I/O device on a single chip  
(d) Register unit and control unit on a single chip
12. Machine instructions are written using which of the following ?
- (a) Bits 0 and 1 only  
(b) Digits 0 to 9 only  
(c) Digits 0 to 9 and the capital alphabets A to Z only  
(d) Digits 0 to 9, the capital alphabets A to Z and certain special characters
13. A good assembly language programmer should use general purpose registers rather than memory in maximum possible ways for data processing. This is because:
- (a) Data processing with registers is easier than with memory  
(b) Data processing with memory requires more instructions in the program than that with registers  
(c) Of limited set of instructions for data processing with memory  
(d) Data processing with registers takes fewer cycles than that with memory
14. Which of the following is not correct?
- (a) Bus is a group of wires  
(b) Bootstrap is a technique or device for loading first instruction  
(c) An instruction is a set of bits that defines a computer operation  
(d) An interrupt signal is required at the start of every program
15. Number of address lines necessary to connect 8 k memory chip is
- (a) 10      (b) 11  
(c) 12      (d) 13
16. Micro programming is a technique commonly used to implement
- (a) Data path of a processor  
(b) Cache memory  
(c) Control unit of a processor  
(d) None of the above
17. **Assertion (A)** : Many programmers prefer assembly level programming to machine language programming.
- Reason (R)** : It is possible to efficiently utilize the hardware of the computer in machine language programming.
- (a) Both A and R are individually true and R is the correct explanation of A  
(b) Both A and R are individually true but R is NOT the correct explanation of A  
(c) A is true but R is false  
(d) A is false but R is true
18. Consider the following statements:
1. The process of entering data is called burning in ROM.
  2. ROMs are volatile memories.
  3. ROMs are used in microcontroller security systems.
- Which of these statements are correct?
- (a) 1, 2 and 3      (b) 1 and 2  
(c) 2 and 3      (d) 1 and 3
19. Which one of the following statements is correct?
- (a) RAM is a non-volatile memory whereas ROM is a volatile memory  
(b) RAM is a volatile memory whereas ROM is a non-volatile memory

- (c) Both RAM and ROM are volatile memories but ROM data is not lost when power is switched off
- (d) Both RAM and ROM are non-volatile memories but in RAM data is lost when power is switched off
20. An input port is
- (a) Tri-state buffer with register
- (b) Select logic
- (c) Input device
- (d) Read write memory
21. Every processor must necessarily have
- (a) Data bus
- (b) Data bus and address bus
- (c) Control bus
- (d) Address bus, data bus and control bus
22. Cache memory is logically positioned
- (a) Between CPU and main memory
- (b) Between main memory and secondary memory
- (c) Inside the CPU
- (d) Inside the I/O processor
23. A stack is
- (a) An 8-bit register in the microprocessor
- (b) A 16-bit register in the microprocessor
- (c) A set of memory location in R/W memory reserved for storing information temporarily during the execution of a program
- (d) 16-bit memory address stored in the program counter
24. With 2's complement representation, the range of values that can be represented on the data bus of an 8-bit microprocessor is given by
- (a) -128 to +127      (b) -128 to +128
- (c) -127 to +128      (d) -256 to +256
25. Match List-I (Type of Memory) with List-II (Used As) and select the correct answer using the codes given below the lists:
- | List-I             | List-II           |
|--------------------|-------------------|
| A. DRAM            | 1. Cache memory   |
| B. SRAM            | 2. Main memory    |
| C. Parallel Access | 3. BIOS Registers |
| D. ROM             | 4. CPU registers  |
- Codes:      A      B      C      D
- (a)      1      2      3      4
- (b)      2      1      4      3
- (c)      1      2      4      3
- (d)      2      1      3      4
26. The use of cache in a computer system increases the
- (a) Available memory space for the program
- (b) Available memory space for data
- (c) Average speed of memory access
- (d) Addressing range of CPU
27. The data bus in 8080A/8085 microprocessor is a group of
- (a) Eight bidirectional lines that are used to transfer 8 bits between the microprocessor and its I/O and memory
- (b) Eight lines used to transfer data among the registers
- (c) Eight unidirectional lines that are used for I/O devices
- (d) Sixteen bidirectional lines that are used for data transfer between the microprocessor and memory
28. If an original MIB microcomputer operates at 5.MHz with an 8 bit bus and a newer version operates at 20 MHz with a 32 bit bus, compute (approximately) the maximum speed-up possible.
- (a) 2      (b) 4
- (c) 6      (d) 16

29. The larger the RAM of a computer, the faster is its speed, since it eliminates
- (a) Need for ROM
  - (b) Need for external memory
  - (c) Frequent disk input-outputs
  - (d) Need for a data-wide path

30. The mnemonics used in writing a program is called
- (a) Assembly language
  - (b) Fetch cycle
  - (c) Micro instruction
  - (d) Object program

31. Match List-I with List-II and select the correct answer using the codes given below the lists:

**List-I**

- A. Monitor program
- B. Assembler
- C. Mnemonic
- D. Program counter

**List-II**

- 1. Used to indicate memory location
- 2. A combination of letters, symbols and numerals
- 3. A program that translates symbolic instructions into binary equivalent
- 4. An operating system

<i>Codes:</i>	<b>A</b>	<b>B</b>	<b>C</b>	<b>D</b>
(a)	4	3	2	1
(b)	4	3	1	2
(c)	3	4	1	2
(d)	3	4	2	1

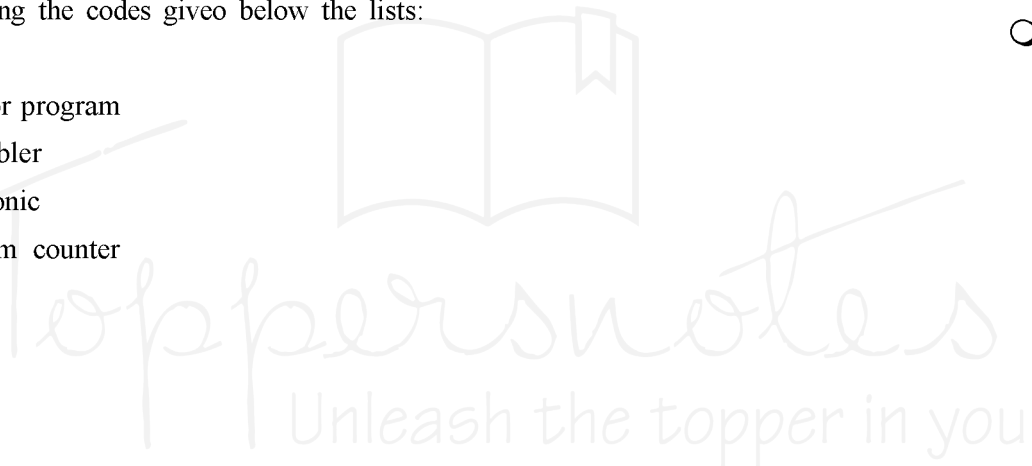

## ANSWERS AND EXPLANATIONS

1. *Ans. (c)*  
An assembler is used for translations of a program from assembly language to machine language.
2. *Ans. (b)*  
An I/O processor control the flow of information between main memory and I/O devices.
3. *Ans.(d)*
4. *Ans.(c)*
5. *Ans.(c)*
6. *Ans.(a)*
7. *Ans.(d)*
8. *Ans.(d)*
9. *Ans. (a)*  
The computer program which converts statements written in high level language to object code is known as interpreter or compiler.
10. *Ans.(c)*
11. *Ans. (d)*  
A microprocessor contains ALU, control unit and register unit. It is a programmable device.
12. *Ans.(a)*
13. *Ans. (d)*  
Data transfer with registers are faster than with memory Normally during opcode fetch data transfer takes place while in memory additional memory read or write cycle is required.
14. *Ans. (d)*  
An interrupt signal is not required at the start of every program. Sometimes it requires, sometimes not.
15. *Ans. (d)*  
Memory size =  $2^n$   
Where n is the number of address lines.
16. *Ans.(c)*  
 $8k = 2^n$   
 $\therefore 2^n = 8 \times 2^{10}$   
 $\Rightarrow 2^n = 2^{13}$
17. *Ans.(b)*  
 $\therefore n = 13$
18. *Ans. (d)*  
ROMs are non volatile as these can be reproduced on restoration of power.
19. *Ans. (b)*
20. *Ans. (a)*
21. *Ans. (d)*
22. *Ans. (c)*
24. *Ans. (c)*
25. *Ans. (a)*
26. *Ans. (c)*
27. *Ans. (d)*
28. *Ans. (d)*  
The data bus in 8080A/8085 microprocessor is a group of sixteen bidirectional lines that are used for data transfer between the microprocessor and memory.
30. *Ans. (d)*  
Bus expansion increases data flow by a factor of  $32/8 = 4$ . Likewise, operating at a higher clock-speed causes a speed-up of at most  $20/5 = 4$ . Assuming that operating system and components support it, a speed up of  
 $4 \times 4 = 16$ .
31. *Ans. (c)*  
Since if RAM is not enough, data has to be stored on disk and hence disk I/O is needed which is wastefull of time.
33. *Ans. (a)*
34. *Ans. (a)*

# MICROPROCESSOR 8085

## THEORY

### 1. INTRODUCTION TO 8085 MICROPROCESSOR

- (1) 8085 A is commonly known as 8085 microprocessor.
- (2) It is based on NMOS technology.
- (3) It is **8-bit** microprocessor.
- (4) Bit of microprocessor → size of ALU (accumulator) is known as bit of microprocessor.
- (5) No. of data bits execute in one machine cycle is known as bit of microprocessor.

8 bit = Byte  
 4 bit = nibble  
 2 bit = Dit/Dite  
 2<sup>10</sup> = Kilo  
 2<sup>20</sup> = Mega  
 2<sup>30</sup> = Giga

2<sup>40</sup> = Tera  
 2<sup>50</sup> = Peta  
 2<sup>60</sup> = Exa  
 2<sup>70</sup> = Zetta  
 2<sup>80</sup> = Yotta

Microprocessor	Bit of Microprocessor	Technology
4004	4 bit	PMOS
8008	8 bit	NMOS
8080	8 bit	NMOS
8085	8 bit	NMOS
8085	16 bit	HMOS
		H- High density channel
8088	8/16 bit	HMOS

- (6) 8088-externally 8 bit but internally 16 bit microprocessor.

80186	16 bit	} CMOS/ Bi CMOS	Pentium	32/64 bit	} Bi CMOS
80286	16 bit		Pentium Pro	32/64bit	
80386	32 bit		P-II	64bit	
80486	32 bit		P-III	64bit	
		P-IV	64bit		

(7) 8085 is the advanced version of 8080 microprocessor.

→ Backward compatible ← Upward compatibility

Instruction set  $\equiv$  Instruction set of 8080 + RIM + SIM

RIM - Read interrupt mask.

SIM - Set interrupt mask.

(8)  $V_{cc} = +5V$

Operating frequency = 3 MHz =  $f_{Op}$

speed  $\propto$  operating frequency

$$\text{speed} \propto \frac{1}{\text{total time}} \propto \frac{1}{4T} \propto \frac{1}{4/f} \propto f_{Op}$$

## 2. PIN DIAGRAM OF 8085

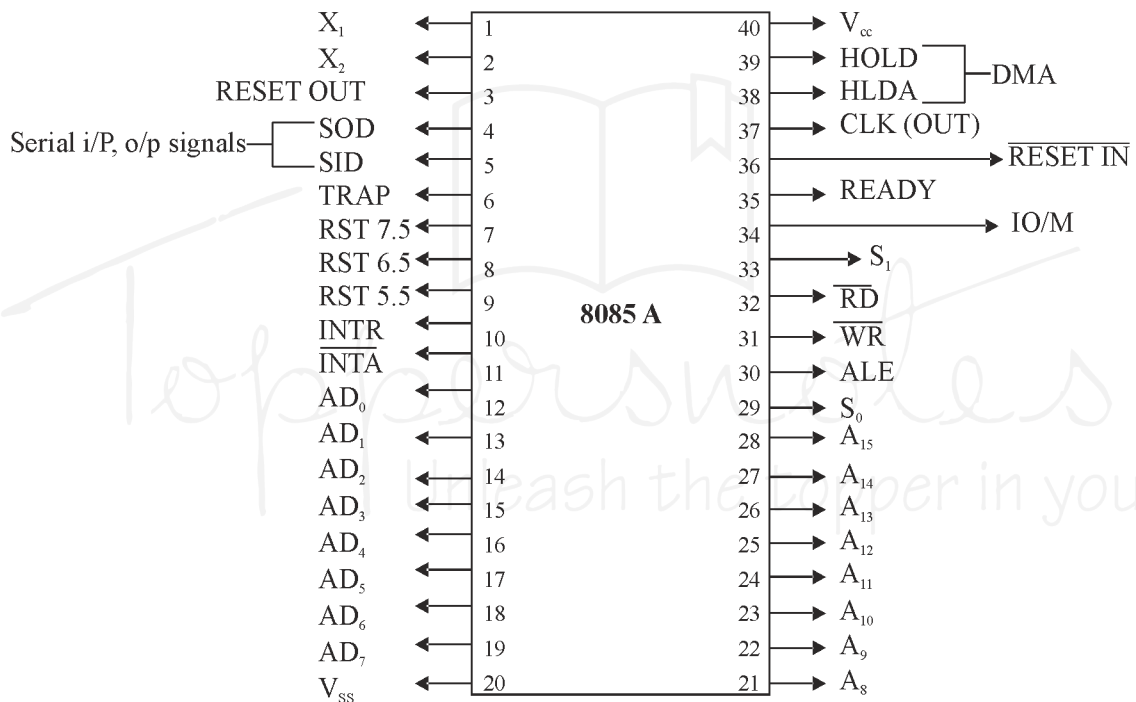

## 3. MEMORY

(1) Program, data and stack memories occupy the same memory space. The total addressable memory size is 64 KB.

(2) **Program memory:** program can be located anywhere in memory. Jump, branch and call instructions use 16-bit addresses, i.e. they can be used to jump/branch anywhere within 64 KB. All jump/branch instructions use absolute addressing.

(3) **Data memory :** The processor always uses 16-bit addresses so that data can be placed anywhere.

(4) **Stack memory :** It is limited only by the size of memory. Stack grows downward.

(5) First 64 bytes in a zero memory page should be reserved for vectors used by RST instructions.

#### 4. SIGNAL GROUPS OF 8085

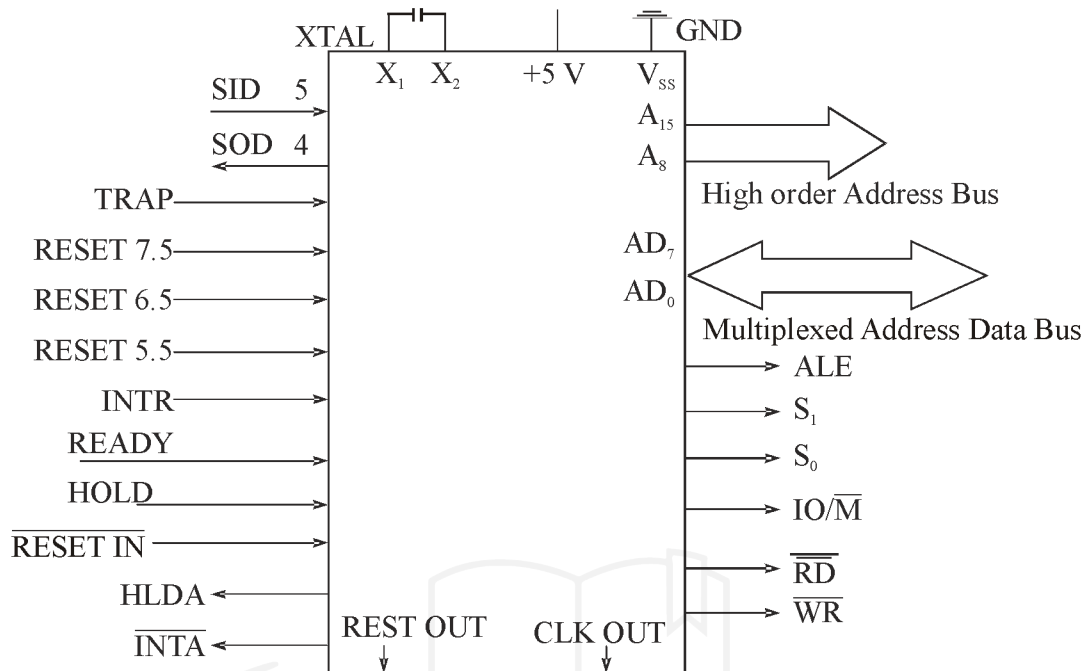

#### 5. INTERRUPTS

- (1) The processor has 5 interrupts. They are presented below in the order of their priority (from lowest to highest):
- (2) **INTR** is maskable 8080 A compatible interrupt. When the interrupt occurs the processor fetches from the bus one instruction, usually one of these instructions:
- (3) One of the 8 RST instructions ( $RST_0 - RST_7$ ). The processor saves current program counter into stack and branches to memory location  $N * 8$  (where N is a 3-bit number from 0 to 7 supplied with the RST instruction).
- (4) **CALL** instruction (3 byte instruction). The processor calls the subroutine, address of which is specified in the second and third bytes of the instruction).
- (5) **RST5.5** is a maskable interrupt. When this interrupt is received the processor saves the contents of the PC register into stack and branches to 2CH (hexadecimal) address.
- (6) **RST 6.5** is a maskable interrupt. When this interrupt is received the processor saves the contents of the PC register into stack and branches to 34H (hexadecimal) address.
- (7) **RST 7.5** is a maskable interrupt. When this interrupt is received the processor saves the contents of the PC register into stack and branches to 3CH (hexadecimal) address.
- (8) **TRAP** is a non-maskable interrupt. When this interrupt is received the processor saves the contents of the PC register into stack and branches to 24H (hexadecimal) address.
- (9) All maskable interrupts can be enabled or disabled using EI and DI instructions. RST 5.5, RST 6.5 and RST 7.5 interrupts can be enabled or disabled individually using SIM instruction.

## **6. RESET SIGNALS**

### **6.1 RESET IN:**

When this signal goes low, the program counter (PC) is set to zero, microprocessor is reset and resets the interrupt enable and HLDA flip-flops.

- (a) The data and address buses and the control lines are 3-stated during RESET and because of asynchronous nature of RESET, the processor internal registers and flags may be altered by RESET with unpredictable results.
- (b) RESET IN is a Schmitt-triggered input, allowing connection to an R-C network for power-on RESET delay.
- (c) Upon power-up, RESET IN must remain low for at least 10 ms after minimum  $V_{CC}$  has been reached.
- (d) For proper reset operation after the power-up duration, RESET IN should be kept low a minimum of three clock periods.
- (e) The CPU is held in the reset condition as long as RESET IN is applied. Typical Power-on RESET RC values  $R_1 = 75k\Omega$ ,  $C_1 = 1\mu F$ .

### **6.2 RESET OUT:**

This signal indicates that microprocessor is being reset. This signal can be used to reset other devices. The signal is synchronized to the processor clock and lasts an integral number of clock periods.

## **7. SERIAL COMMUNICATION SIGNAL**

### **7.1 SID- SERIAL INPUT DATA LINE:**

The data on this line is loaded into accumulator bit 7 whenever a RIM instruction is executed.

### **7.2 SOD-SERIAL OUTPUT DATA LINE:**

The SIM instruction loads the value of bit 7 of the accumulator into SOD latch if bit 6 (SOE) of the accumulator is 1.

## **8. DMA SIGNALS**

### **8.1 HOLD:**

Indicates that another master is requesting the use of the address and data buses. The CPU, upon receiving the hold request, will relinquish the use of the bus as soon as the completion of the current bus transfer.

- (a) Internal processing can continue. The processor can regain the bus only after the HOLD is removed.
- (b) When the HOLD is acknowledged, the Address, Data RD, WR and Input output /Memory ( $IO/\bar{M}$ ) lines are 3-stated

### **8.2 HLDA: Hold Acknowledge:**

Indicates that the CPU has received the HOLD request and that it will relinquish the bus in the next clock cycle.

HLDA goes low after the Hold request is removed. The CPU takes the bus one half-clock cycle after HLDA goes low.